

VACUUM EJECTORS

Product Features

- 1 Available in both standard and low vacuum pressure options.
- 2 Threaded port or One Touch Push-in ports.
- 3 Box or in-line design.
- 4 Built-in silencer with box design.
- 5 Compact.
- 6 Choice of 7 nozzle sizes.
- 7 Lightweight.
- 8 Mounting holes for easy fixing on machinery.

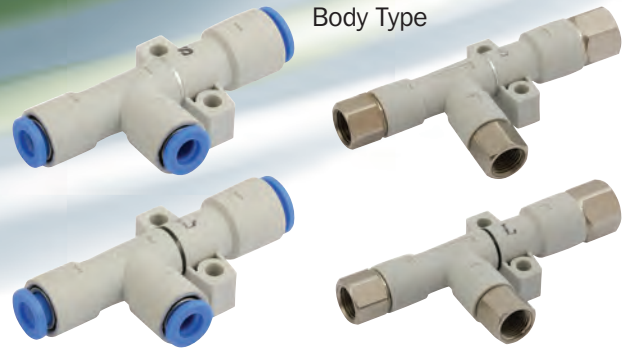

Body Type

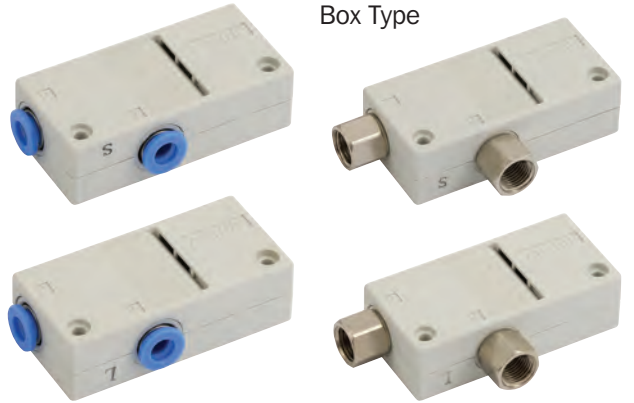

Box Type

Ordering Code

K Z H	—	0 5	—	D	—	S	—	0 6	—	0 6	—	0 6
Model		Nozzle Diameter (mm)		Type		Maximum Vacuum Pressure (kPa)		Supply Port Size		Vacuum Port Size		Exhaust Port Size
KZH : Vacuum Ejector		05 : 0.5		B : Box Type		S : -88		06 : 06mmØ		06 : 06mmØ		06 : 06mmØ
		07 : 0.7		D : Body Type		L : -48		08 : 08mmØ		10 : 10mmØ		08 : 08mmØ
		10 : 1.0						10 : 10mmØ		12 : 12mmØ		10 : 10mmØ
		13 : 1.3						12 : 12mmØ		01 : Rc 1/8		12 : 12mmØ
		15 : 1.5						01 : Rc 1/8		02 : Rc 1/4		01 : Rc 1/8
		18 : 1.8						02 : Rc 1/4		03 : Rc 3/8		02 : Rc 1/4
		20 : 2.0						03 : Rc 3/8		04 : Rc 1/2		03 : Rc 3/8
												04 : Rc 1/2

VACUUM EJECTORS

Exhaust / Flow Characteristics

— Vacuum pressure - - - Air consumption - - - Flow rate

KZH15 S

Max. vacuum pressure: -88 kPa

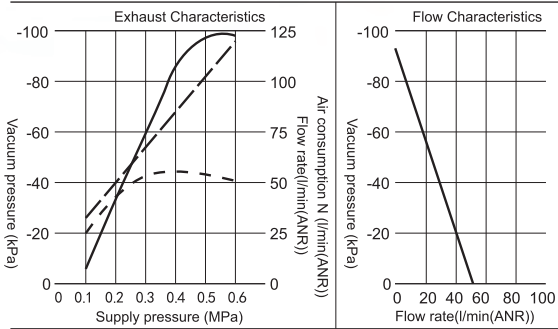

KZH15 L

Max. vacuum pressure: -53 kPa

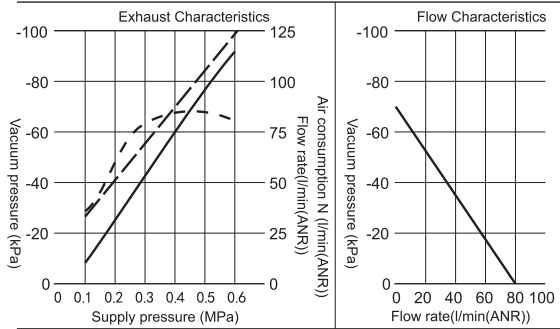

KZH18 S

Max. vacuum pressure: -88 kPa

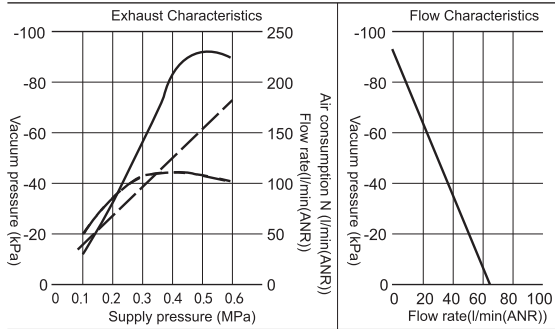

KZH18 L

Max. vacuum pressure: -53 kPa

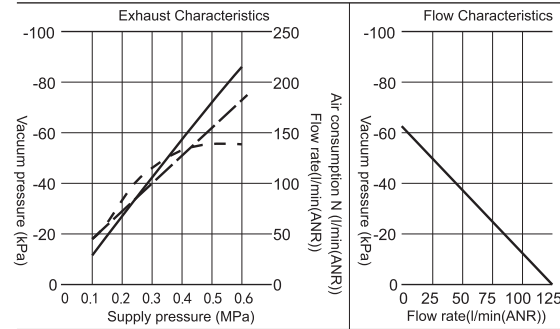

KZH20 S

Max. vacuum pressure: -88 kPa

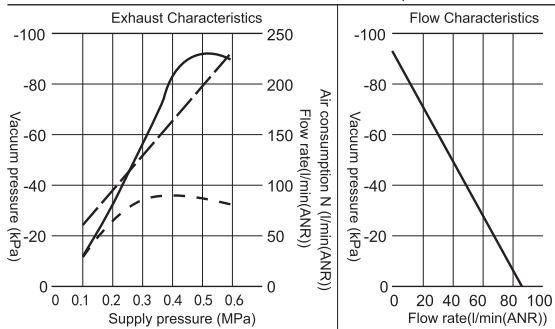

KZH20 L

Max. vacuum pressure: -53 kPa

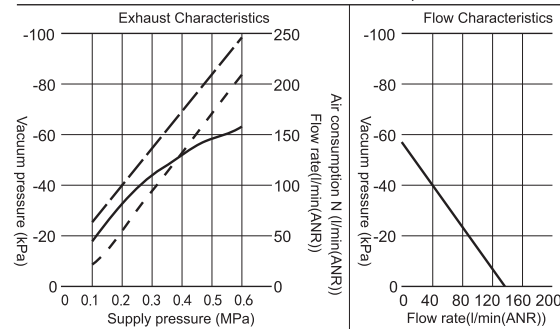

VACUUM EJECTORS

Dimensions

All sizes are in millimetres unless stated otherwise.

Body Type, One Touch Push-in

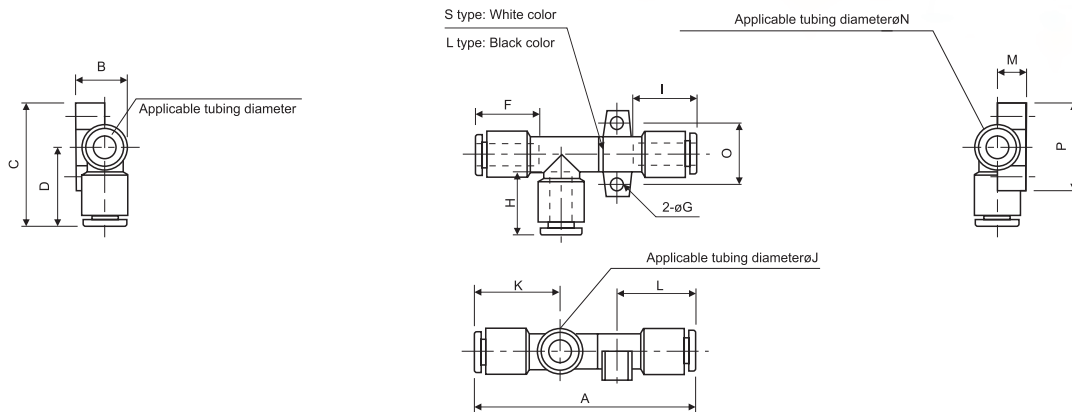

Model	A	B	C	D	ØE	F	ØG	H	I	ØJ	K	L	M	ØN	O	P
KZH05DS-06-06-06	58.5	14.2	34	22	6	17	3.2	17	17	6	24	21	7.8	6	17	24
KZH05DL-06-06-06	58.5	14.2	34	22	6	17	3.2	17	17	6	24	21	7.8	6	17	24
KZH07DS-06-06-06	61	14.2	34	22	6	17	3.2	17	17	6	24	22	7.8	6	17	24
KZH07DL-06-06-06	61	14.2	34	22	6	17	3.2	17	17	6	24	22	7.8	6	17	24
KZH10DS-06-06-08	66	17.2	37	23	6	17	4.2	17	18.5	6	28	24.5	9.6	8	20	28
KZH10DL-06-06-08	70	17.2	37	23	6	17	4.2	17	18.5	6	28	24.5	9.6	8	20	28
KZH13DS-08-10-10	74.5	20	42.5	27.5	8	18.5	4.2	21	21	10	30	27	10.7	10	22	30
KZH13DL-08-10-10	79.5	20	42.5	27.5	8	18.5	4.2	21	21	10	30	27	10.7	10	22	30
KZH15DS-10-12-12	93.3	22.45	47	29.5	10	21	4.2	22	22	12	35	32.8	12	12	27	35
KZH15DL-10-12-12	93.3	22.45	47	29.5	10	21	4.2	22	22	12	35	32.8	12	12	27	35

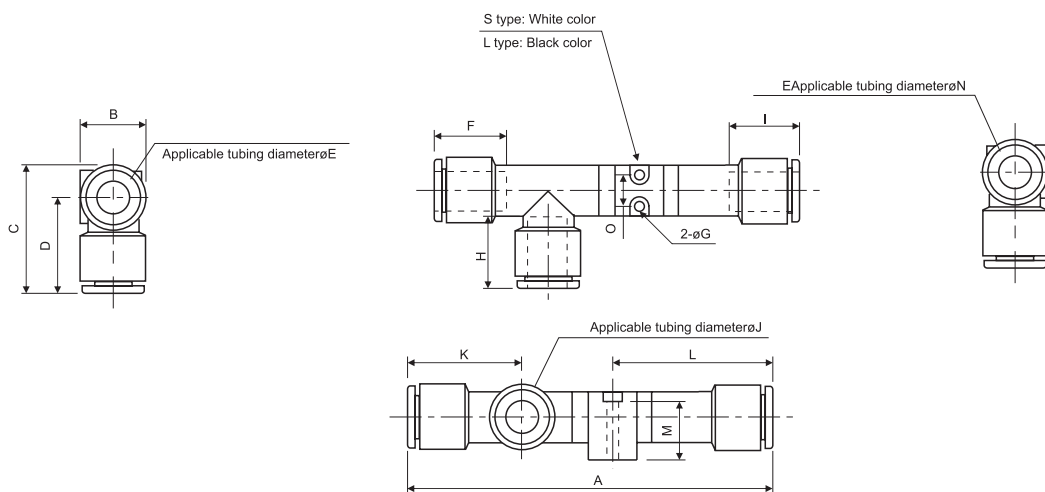

Model	A	B	C	D	ØE	F	ØG	H	I	ØJ	K	L	M	ØN	O
KZH18DS-12-12-12	114	20.95	40.95	30.5	12	22	3.5	22	22	12	35.5	50	17	12	10
KZH18DL-12-12-12	114	20.95	40.95	30.5	12	22	3.5	22	22	12	35.5	50	17	12	10
KZH20DS-12-16-16	124.6	26.75	45.95	32.7	12	22	3.5	25	25	16	38.5	54.3	21.7	16	12
KZH20DL-12-16-16	124.6	26.75	45.95	32.7	12	22	3.5	25	25	16	38.5	54.3	21.7	16	12

VACUUM EJECTORS

Dimensions

All sizes are in millimetres unless stated otherwise.

Body Type, Threaded

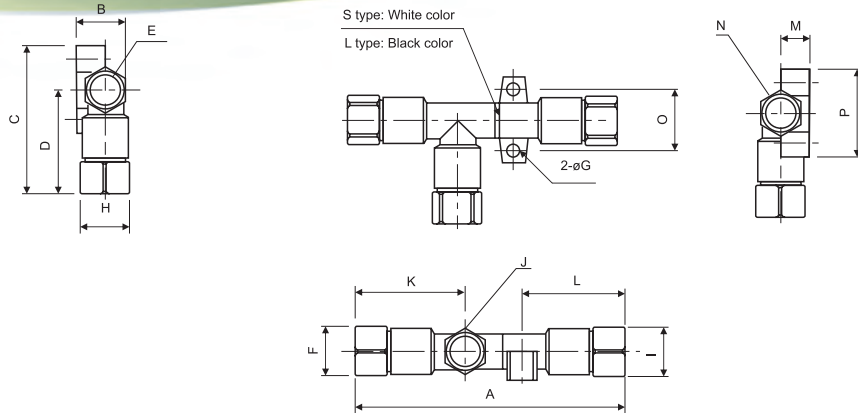

Model	A	B	C	D	ØE	F	ØG	H	I	ØJ	K	L	M	ØN	O	P
KZH05DS-01-01-01	73.5	14.2	41.5	29.5	Rc1/8	12	3.2	12	12	Rc1/8	31.5	28.5	7.8	Rc1/8	17	24
KZH05DL-01-01-01	73.5	14.2	41.5	29.5	Rc1/8	12	3.2	12	12	Rc1/8	31.5	28.5	7.8	Rc1/8	17	24
KZH07DS-01-01-01	76	14.2	41.5	29.5	Rc1/8	12	3.2	12	12	Rc1/8	31.5	29.5	7.8	Rc1/8	17	24
KZH07DL-01-01-01	76	14.2	41.5	29.5	Rc1/8	12	3.2	12	12	Rc1/8	31.5	29.5	7.8	Rc1/8	17	24
KZH10DS-01-01-01	82	17.2	44.5	30.5	Rc1/8	12	4.2	12	12	Rc1/8	33.5	33	9.6	Rc1/8	20	28
KZH10DL-01-01-01	86	17.2	44.5	30.5	Rc1/8	12	4.2	12	12	Rc1/8	33.5	33	9.6	Rc1/8	20	28
KZH13DS-01-02-02	94.5	20	54	39	Rc1/8	14	4.2	17	17	Rc1/4	36.5	38.5	10.7	Rc1/4	22	30
KZH13DL-01-02-02	99.5	20	54	39	Rc1/8	14	4.2	17	17	Rc1/4	36.5	38.5	10.7	Rc1/4	22	30
KZH15DS-02-03-03	116.5	22.45	58.5	41	Rc1/4	17	4.2	19	19	Rc3/8	43	44.5	12	Rc3/8	27	35
KZH15DL-02-03-03	116.5	22.45	58.5	41	Rc1/4	17	4.2	19	19	Rc3/8	43	44.5	12	Rc3/8	27	35

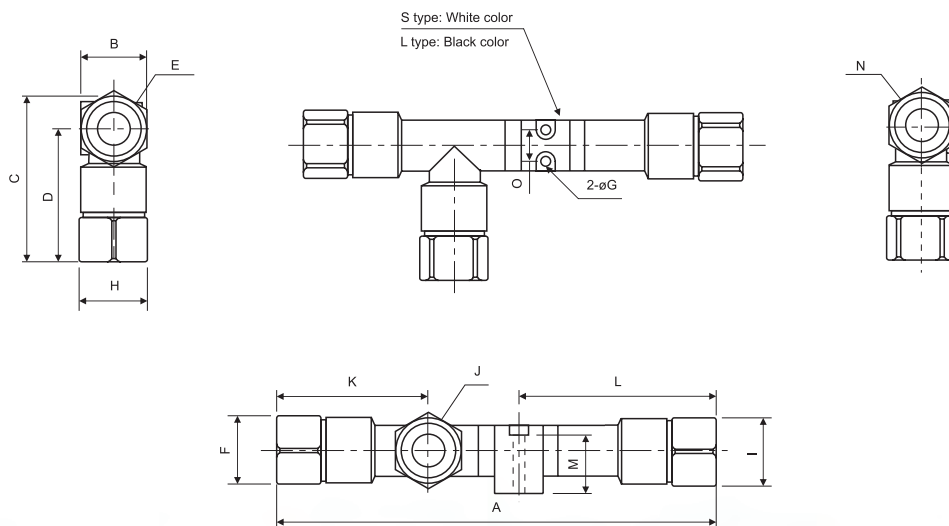

Model	A	B	C	D	ØE	F	ØG	H	I	ØJ	K	L	M	ØN	O
KZH18DS-03-03-03	133	20.95	52.45	42	Rc3/8	19	3.5	19	19	Rc3/8	47	57.5	17	Rc3/8	10
KZH18DL-03-03-03	133	20.95	52.45	42	Rc3/8	19	3.5	19	19	Rc3/8	47	57.5	17	Rc3/8	10
KZH20DS-03-04-04	151.1	26.75	60.95	47.7	Rc3/8	19	3.5	24	24	Rc1/2	50	69.3	22	Rc1/2	12
KZH20DL-03-04-04	151.1	26.75	60.95	47.7	Rc3/8	19	3.5	24	24	Rc1/2	50	69.3	22	Rc1/2	12

VACUUM EJECTORS

Dimensions

All sizes are in millimetres unless stated otherwise.

Box Type, One Touch Push-in

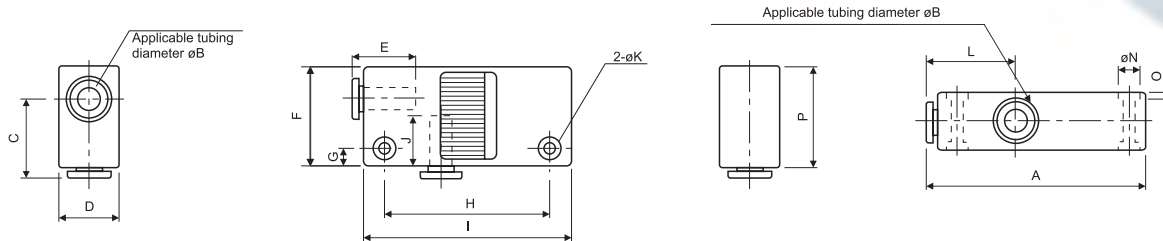

Model	A	ØB	C	D	E	F	G	H	I	J	ØK	L	ØM	ØN	O	P
KZH05	60	6	22	16	17	28	5	47	57	17	3.2	24	6	5.8	2	31
KZH07	60	6	22	16	17	28	5	47	57	17	3.2	24	6	5.8	2	31
KZH10	63	6	23	18	17	29	5	50	60	17	3.2	26	6	5.8	2	32
KZH13	78	8	27.5	23	18.5	35	7	61	75	21	4.2	28	10	7.5	3	38.5

Box Type, Threaded

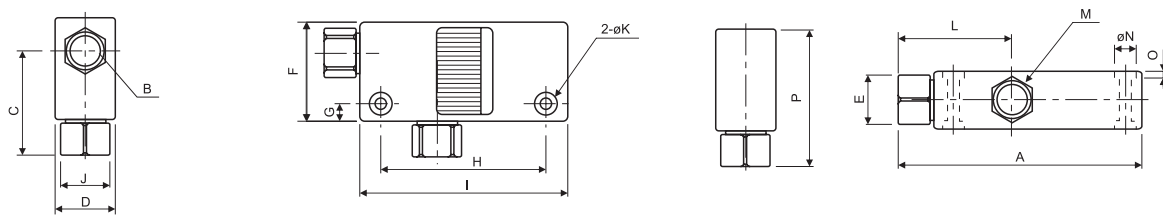

Model	A	ØB	C	D	E	F	G	H	I	J	ØK	L	ØM	ØN	O	P
KZH05	67.5	Rc1/8	29.5	16	12	28	5	47	57	12	3.2	31.5	Rc1/8	5.8	2	38.5
KZH07	67.5	Rc1/8	29.5	16	12	28	5	47	57	12	3.2	31.5	Rc1/8	5.8	2	38.5
KZH10	70.5	Rc1/8	30.5	18	12	29	5	50	60	12	3.2	33.5	Rc1/8	5.8	2	39.5
KZH13	86.5	Rc1/8	39	23	14	35	7	61	75	17	4.2	36.5	Rc1/4	7.5	3	50