



New Headquarters :

MP FILTRI S.p.A. Italy

Via 1° Maggio, n. 3
20060 Pessano con Bornago
(Milano) Italy
Tel. +39.02/95703.1
Fax +39.02/95741497-95740188
email: sales@mpfiltri.com
<http://www.mpfiltri.com>

GREAT BRITAIN

MP FILTRI U.K. Ltd.

Bourton Industrial Park
Bourton on the Water
Gloucestershire GL54 2HQ UK
Phone: +44.01451-822522
Fax: +44.01451-822282
email: sales@mpfiltri.co.uk
<http://www.mpfiltri.co.uk>

GERMANY

MP FILTRI D GmbH

Am Wasserturm 5
D-66265 Heusweiler/Holz
Phone: +49.06806-85022.0
Fax: +49.06806-85022.18
email: service@mpfiltri.de
<http://www.mpfiltri.de>

FRANCE

MP FILTRI FRANCE

B.P. 65
74501 Evian Cedex
Tel: +33.04-50-71-64-80
Telefax: +33.04-50-71-73-32
email: mpfiltrifrance@wanadoo.fr

USA

MP FILTRI USA Inc.

2055 Quaker Pointe Drive
Quakertown, PA 18951
Phone: +1.215-529-1300
Fax: +1.215-529-1902
email: sales@mpfiltriusa.com
<http://www.mpfiltriusa.com>

CANADA

MP FILTRI CANADA Inc.

380 Four Valley Drive Concorde
Ontario Canada L4K 5Z1
Phone: +1.905-303-1369
Fax: +1.905-303-7256
email: mail@mpfiltricanada.com
<http://www.mpfiltricanada.com>

RUSSIAN FEDERATION

MP FILTRI RUSSIA

Shenkursky proed, 3
Building B, office 308
127349 Moscow
Phone/Fax: +7 (495) 601-34-83
GSM: +7 (495) 502-54-11
<http://www.mpfiltri.ru>

CHINA

MP FILTRI

P.O. Box 418-008
Shanghai
Phone: +86.21-57120700
Fax: +86.21-57127200
sales@mpfiltrichina.com

Pressure filter

SERIES

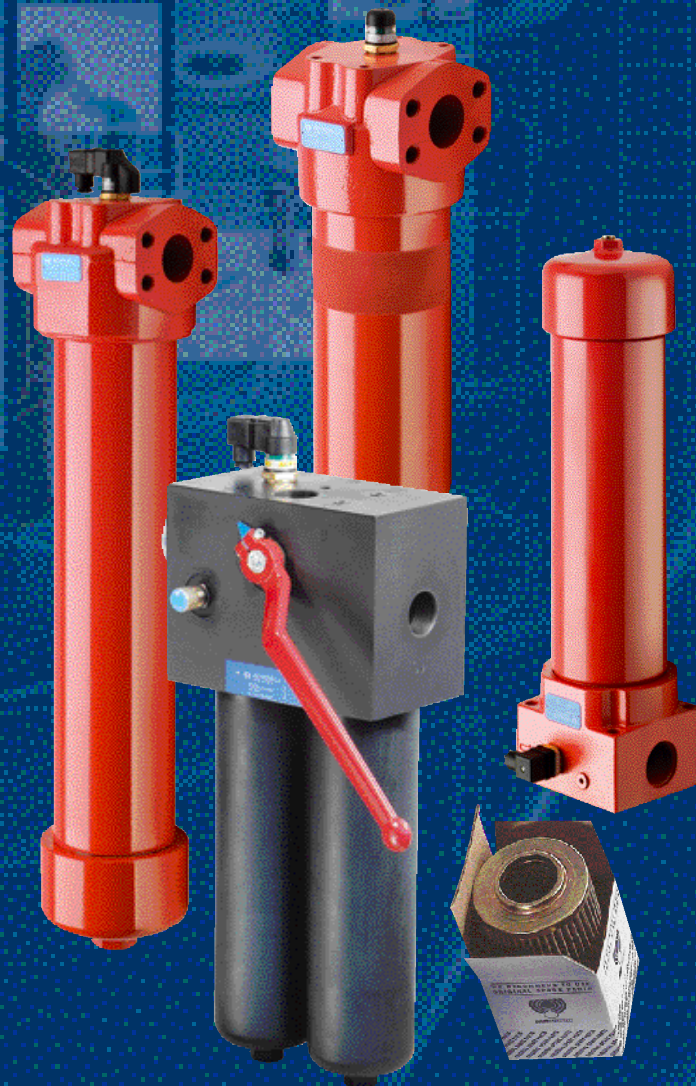

Maximum working pressure 420 bar

Flow rates to 700 l/min

FILTRI®



Product Programme



Contamination monitoring products

- Particle counters calibrated to ISO 11171
- On-line and In-line counting
- Bottle sampler options
- Remote operating capability
- Windows based software package RS 232 - RS 485 digital bus



Suction Filters

- Flow rate to 620 lpm
- Mounting:
- Tank immersed
 - In-line external
 - In tank with shut off valve



Return Filters

- Flow rates to 1500 l/min
 - Pressure to 20 bar
- Mounting:
- In-line external
 - Tank top
 - In single and duplex designs



Pressure Filters

- Flow rates to 700 l/min
 - Pressure from 110 bar to 420 bar
- Mounting:
- In-line
 - Manifold
 - In single and duplex designs



Spin-On filters

- Flow rates to 300 l/min
 - Pressure to 35 bar
- Mounting:
- In-line
 - Tank top

Product Programme



Stainless Steel Pressure Filters

- Flow rates to 100 l/min
- Pressure from 350 bar to 700 bar

Mounting:

- In-line
- Manifold
- In single and duplex designs



In-line Filters

- Flow rates to 2600 l/min
- Pressures to 50 bar

Mounting:

- In-line
- Parallel manifold version
- In single and duplex designs



Filtration units

- Flow rates from 15 l/min to 200 l/min
- In static and mobile designs



Accessories

- Oil filter and air breather plugs
- Optical and electrical level gauges
- Pressure gauge valve selectors
- Pipe fixing brackets
- Pressure gauges



Mechanical Products

- Aluminium bell housings for motors from 0.12 Kw to 400 Kw
- Couplings in aluminium - cast iron - steel
- Damping rings
- Support feet
- Aluminium tanks
- Inspection doors

FHP



SERIES FHP

**Working pressure
420 bar**

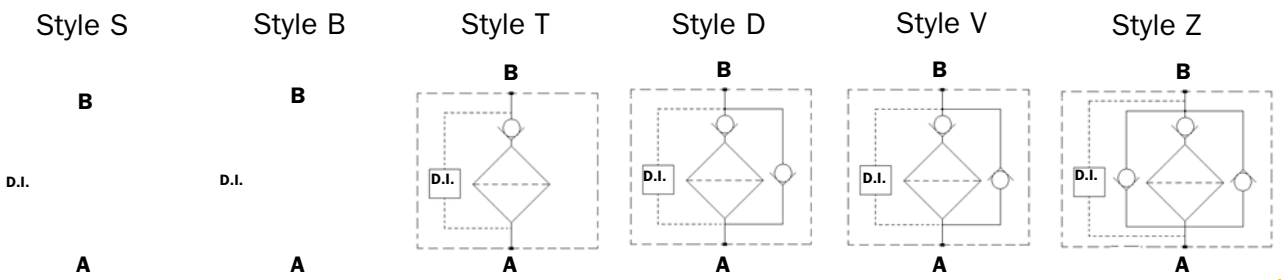
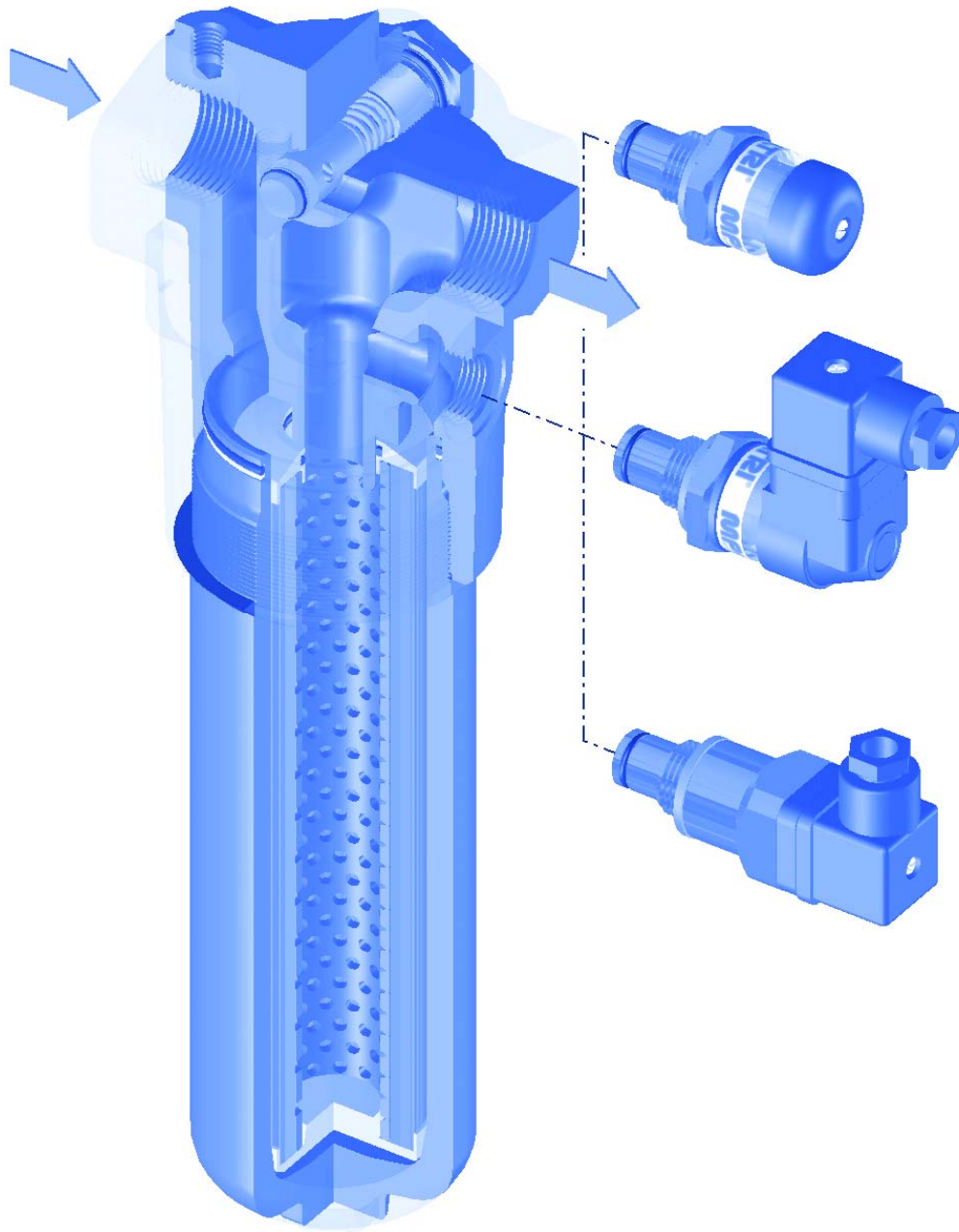

Technical data

Filter body (Materials)

- Head: Cast iron (chemical heat treatment)
- Housing: Steel (chemical heat treatment)
- Bypass valve: Brass
- Reverse Flow : Steel (only for series 320)

Pressure

- Maximum operating pressure: 420 bar (42 MPa)
- Test pressure: 630 bar (63 MPa)
- Burst pressure: 1250 bar (125 MPa)
- Pulsed pressure fatigue test 1,000,000 of cycles with pressure from 0 to 420 bar (42 MPa)

Temperature

- From -25°C to + 110°C

Bypass valve

- Opening pressure 6 bar ±10%
- Other opening pressures on request.

Elements type ≥p

- Elements in microfibre series NR : 20 bar
- Elements in microfibre series H-S : 210 bar
- Elements in stainless steel mesh series N : 20 bar
- Oil flow from exterior to interior.

Seals

- Standard Nitrile (NBR) series A
- Optional FPM series V

Weights without filter elements (kg.)

Length	1	2	3	4
• FHP 065	3.9	4.2	5.7	—
• FHP 135	7.5	9.4	12	—
• FHP 320/321	14.5	16.5	22.5	25.5

Filter internal volumes (dm³)

Length	1	2	3	4
• FHP 065	0.35	0.40	0.60	—
• FHP 135	0.55	0.85	1.20	—
• FHP 320/321	1.25	1.95	2.80	3.50

Connections

In-line Inlet/Outlet
Style FHP 321 inlet/outlet 90°

Compatibility

- Bodies compatible with:
Mineral oils to ISO 2943 - aqueous emulsions
Synthetic fluids, water glycol.
- Filter elements compatible with:
Mineral oils to ISO 2943 - aqueous emulsions
Synthetic fluids, water glycol.
- Nitrile (NBR) seals series A, compatible with:
Mineral oils to ISO 2943 - aqueous emulsions
Synthetic fluids, water glycol.
- V series FPM seals, compatible with:
Synthetic fluids type HS-HFDR-HFDS-HFDU.

Filter Element Area

Filter element in stainless steel mesh
Length

Type	1	2	3	4
HP065	374	530	1064	-
HP135	950	2020	2700	-
HP320	1650	3645	5970	8280

Values expressed in cm²

Pressure drops ≥p Housing

The curves are plotted using mineral oil with density of 0.86 kg/dm³ to ISO 3968.

≥p varies proportional with density.

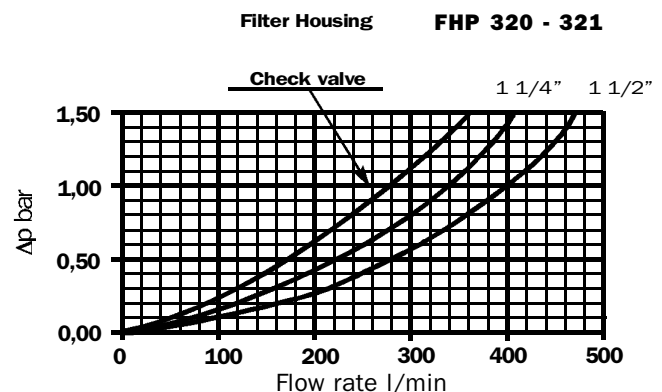
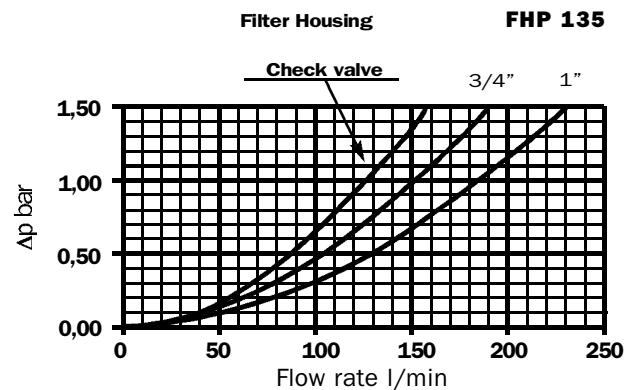
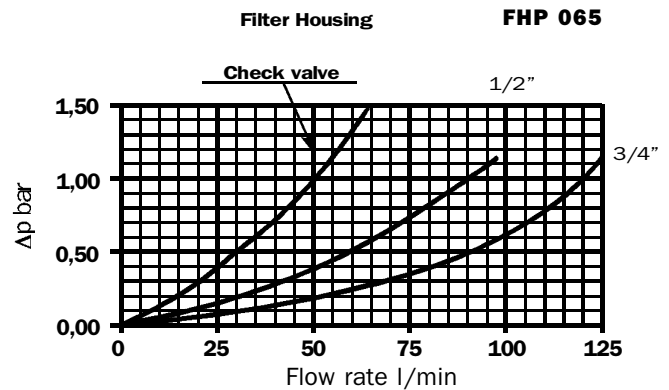

Valves

Pressure drop in bypass valve

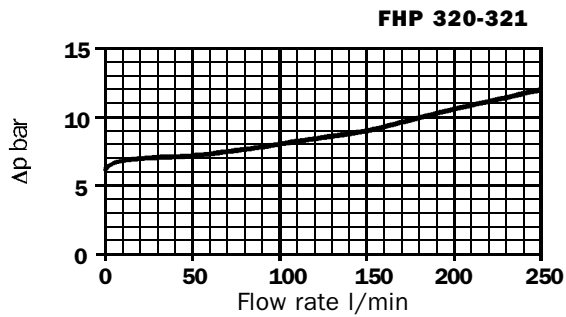
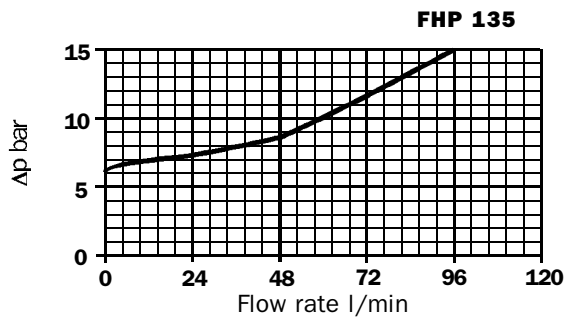
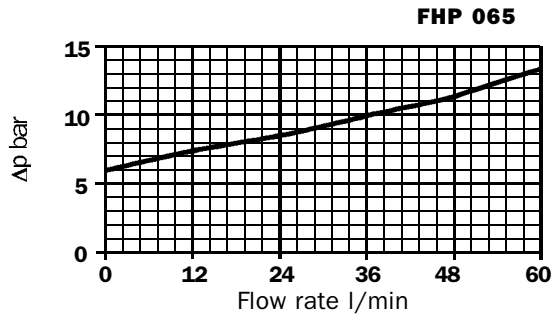

Pressure drop in reverse flow valves

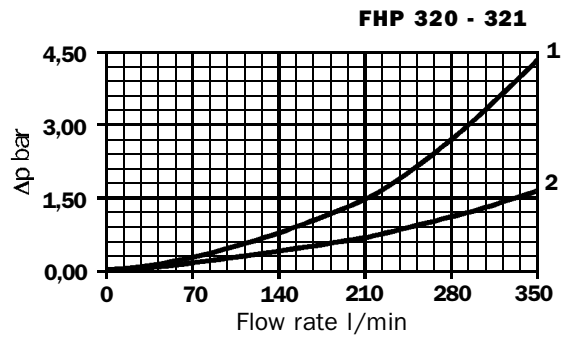

- 1 - Reverse Flow
- 2 - In filter direction

Dimensions

FHP065

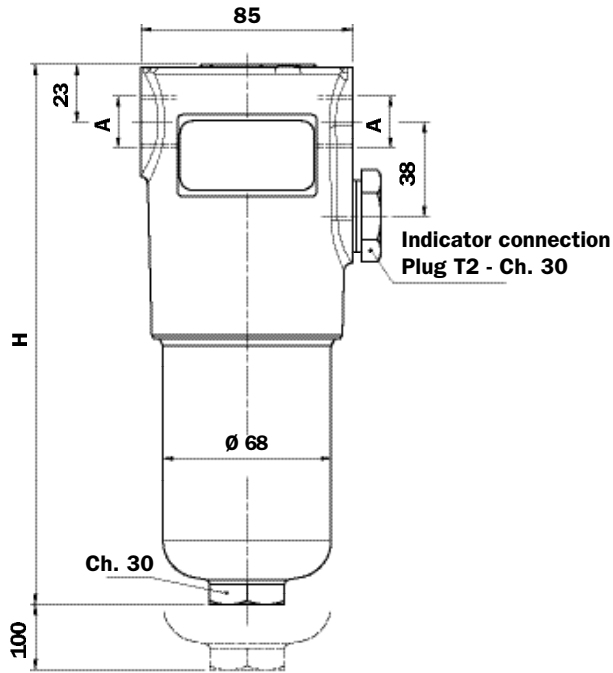

Recommended maximum flow rate

- Pressure drop of complete filter equal to ≥ 1.5 bar.
- Oil kinematic viscosity 30 mm²/s (cSt).
- Density 0.86 kg/dm³.
- Connections of filter under test G 3/4".

Filter element type	Flow rate l/min Series N	Flow rate l/min Series H	Filter Length
A03	23	22	1
A06	30	23	
A10	48	43	
A16	53	50	
A25	72	68	
M25	105	-	2
A03	31	30	
A06	45	35	
A10	60	57	
A16	64	63	
A25	82	77	3
M25	106	-	
A03	53	52	
A06	61	58	
A10	79	78	
A16	84	83	3
A25	94	93	
M25	108	-	

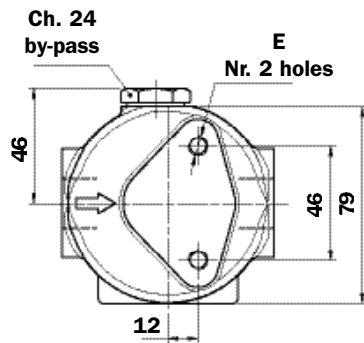

A Threaded Connections	E Depth 15 mm
G 1/2"	M8
G 3/4"	M8
1/2" NPT	5/16" UNC
3/4" NPT	5/16" UNC
SAE 8 (3/4" - 16 UNF)	5/16" UNC
SAE 12 (1 1/16" - 12 UN)	5/16" UNC

Filter Length	H mm
1	200
2	230
3	330

FHP135

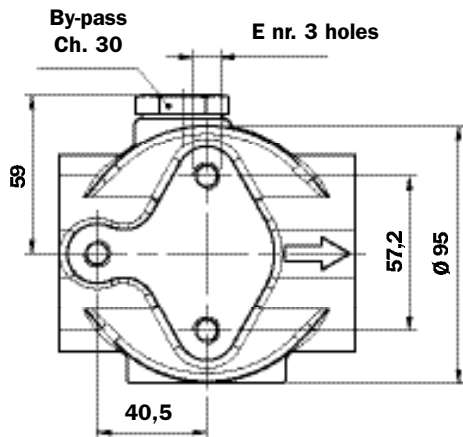
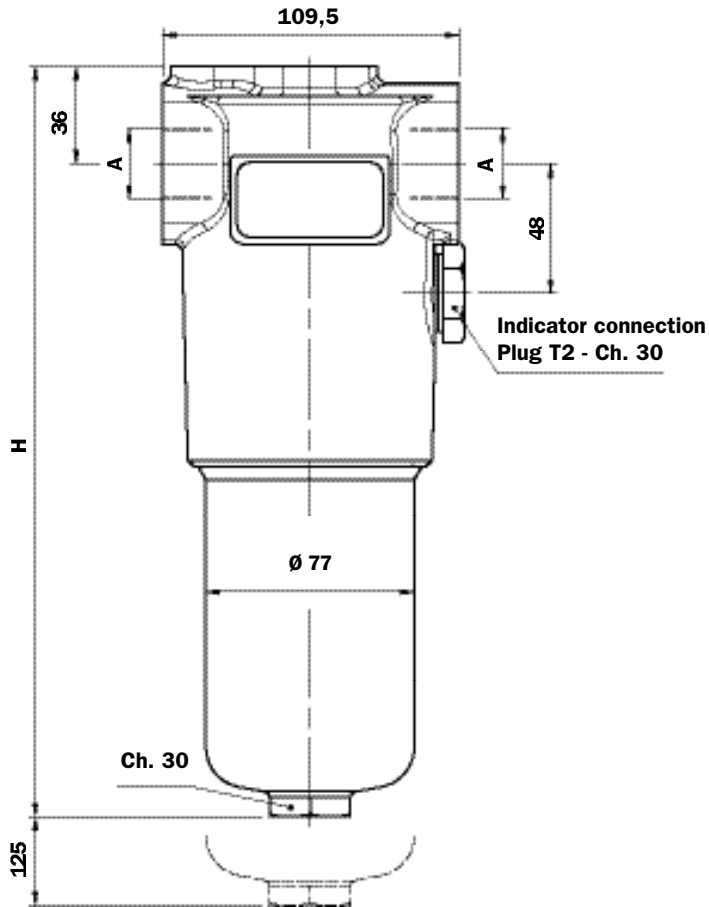

Recommended maximum flow rate

- Pressure drop of complete filter equal to $\geq p$ 1.5 bar.
- Oil kinematic viscosity 30 mm²/s (cSt).
- Density 0.86 kg/dm³.
- Connections of filter under test G 1".

Filter element type	Flow rate l/min Series N	Flow rate l/min Series H	Filter Length
A03	69	50	1
A06	74	57	
A10	120	98	
A16	129	101	
A25	171	156	
M25	200	-	2
A03	110	91	
A06	117	110	
A10	148	136	
A16	151	139	
A25	208	175	3
M25	230	-	
A03	150	126	
A06	153	140	
A10	192	170	
A16	195	179	3
A25	213	196	
M25	232	-	

A Threaded Connections	E Depth 15 mm
G 3/4"	M10
G 1"	M10
3/4" NPT	3/8" UNC
1 NPT	3/8" UNC
SAE 12 (1 1/16"- 12 UN)	3/8" UNC
SAE 16 (1 5/16"- 12 UN)	3/8" UNC

A Flanged Connections	B Depth 15 mm
3/4" SAE 3000 psi/M	M10
1" SAE 3000 psi/M	M10
3/4" SAE 3000 psi/UNC	3/8" UNC
1" SAE 3000 psi/UNC	3/8" UNC
3/4" SAE 6000 psi/M	M10
3/4" SAE 6000 psi/UNC	3/8" UNC

Filter Length	H mm
1	260
2	373
3	448

FHP320/321

Only for FHP 320 length 4

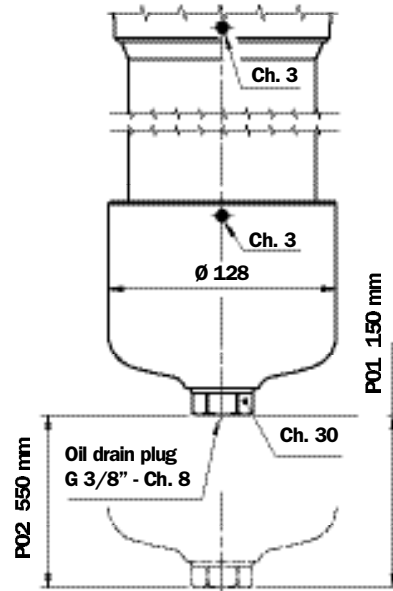
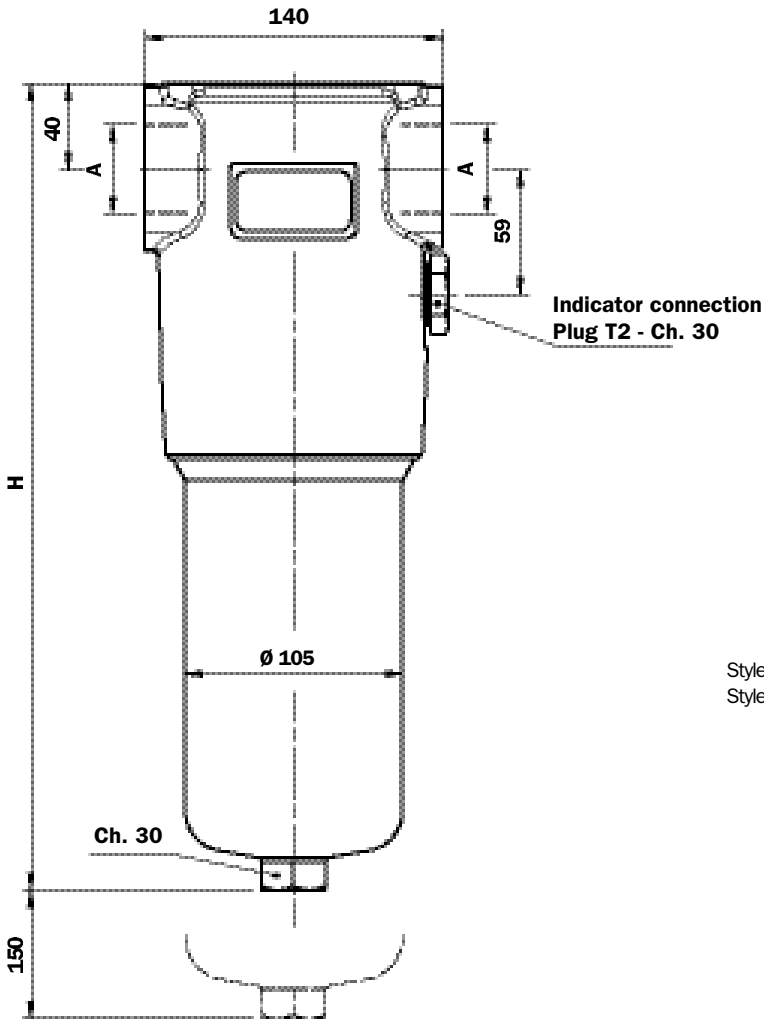

Style P01 standard maintenance from head.
 Style P02 maintenance option from housing base.

FHP 320

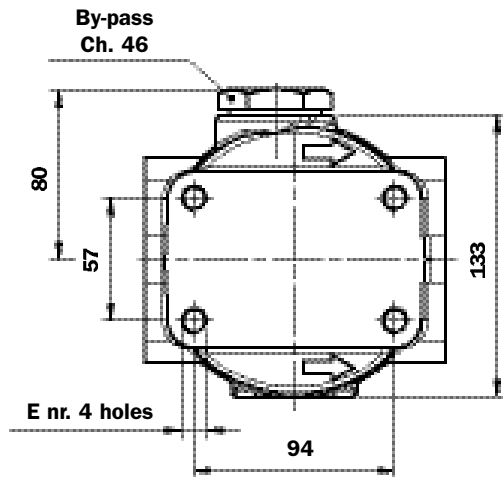

FHP 321 Top Outlet

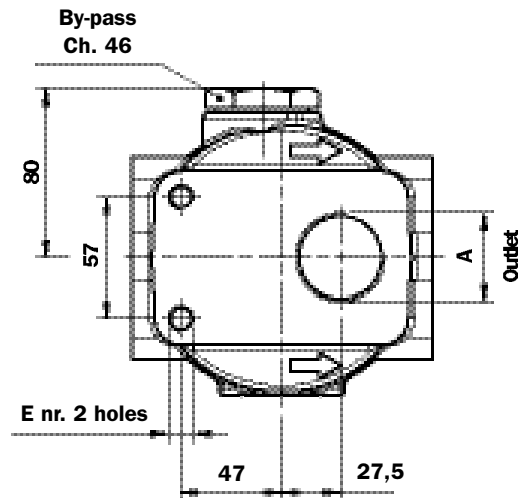

Recommended maximum flow rate

- Pressure drop of complete filter equal to \geq 1.5 bar.
- Oil kinematic viscosity 30 mm²/s (cSt).
- Density 0.86 kg/dm³.
- Connections of filter under test G 1 1/2".

Filter element type	Flow rate l/min Series N	Flow rate l/min Series H	Filter Length
A03	126	107	1
A06	137	112	
A10	230	185	
A16	274	193	
A25	330	292	
M25	425	-	
A03	248	192	2
A06	270	220	
A10	376	300	
A16	395	312	
A25	440	378	
M25	445	-	
A03	319	255	3
A06	353	300	
A10	427	367	
A16	440	375	
A25	450	417	
M25	465	-	
A03	354	298	4
A06	375	320	
A10	430	375	
A16	447	382	
A25	467	422	
M25	475	-	

A Threaded Connections	E Depth 15 mm
G 1 1/4"	M12
G 1 1/2"	M12
1 1/4" NPT	1/2" UNC
1 1/2" NPT	1/2" UNC
SAE 20 (1 5/8"- 12 UN)	1/2" UNC
SAE 24 (1 7/8"- 12 UN)	1/2" UNC

A Flanged Connections (For FHP 320)	E Depth 15 mm
1 1/4" SAE 3000 psi/M	M12
1 1/2" SAE 3000 psi/M	M12
1 1/4" SAE 3000 psi/UNC	1/2" UNC
1 1/2" SAE 3000 psi/UNC	1/2" UNC
1 1/4" SAE 6000 psi/M	M12
1 1/4" SAE 6000 psi/UNC	1/2" UNC

Filter Length	H mm
1	298
2	422
3	554
4	709

Spare parts FHP

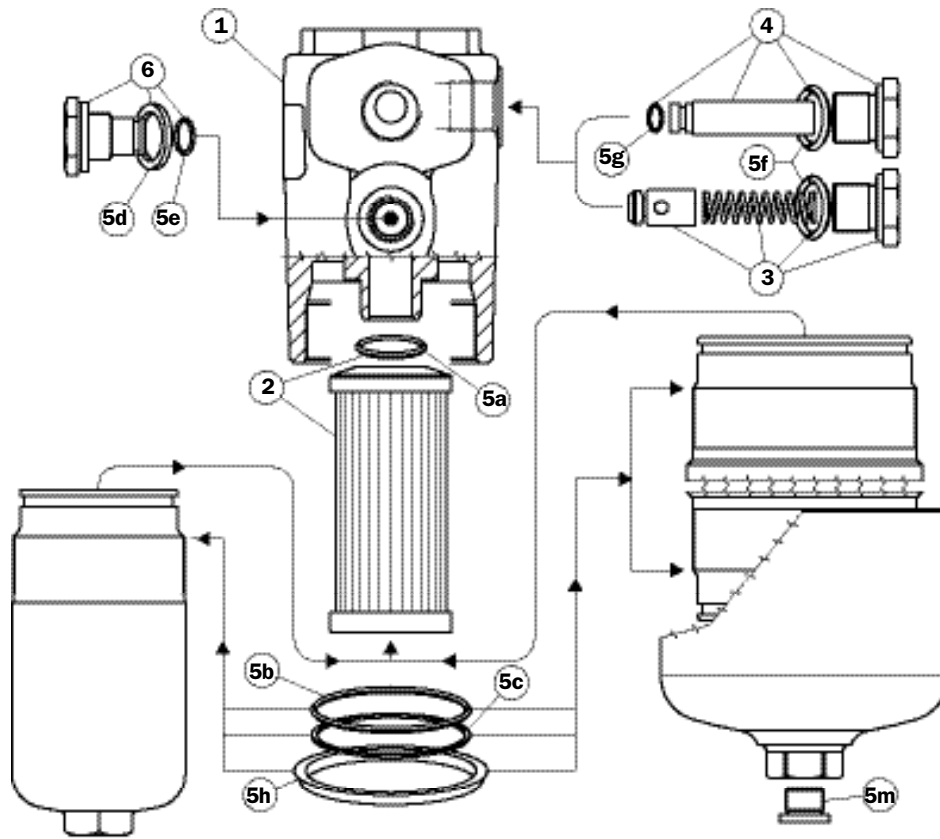

Pos.	Description	Qty.	FHP Series FILTER					
			065 1 - 2 - 3		135 1 - 2 - 3		320 1 - 2 - 3 - 4	
1	Complete filter	1	See order table					
2	Filter element	1	See order table					
3	Bypass assembly	1	02001116 (NBR) 02001136 (FPM)	02001117 (NBR) 02001137 (FPM)	02001118 (NBR) 02001138 (FPM)			
4	No bypass assembly	1	02001142 (NBR) 02001139 (FPM)	02001143 (NBR) 02001392 (FPM)	02001144 (NBR) 02001395 (FPM)			
5	Seals kit	1	NBR 02050265	FPM 02050276	NBR 02050269	FPM 02050280	NBR 02050272	FPM 02050283
5a	Filter element O-Ring	1	OR 4100 Ø 24.99 x 3.53		OR 3106 Ø 26.65 x 2.62		OR 144 Ø 39.69 x 3.53	
5b	O-Ring for housing	1	OR 159 Ø 55.56 x 3.53		OR 3256 Ø 64.77 x 2.62		2 pcs.	OR 3350 Ø 88.57 x 2.62
5c	Anti-extrusion ring	1	Parbak 227 Ø 54.53 x 3		Parbak 144 Ø 63.96 x 2.18		2pcs.	Parbak 153 Ø 89.36 x 2.18
5d	Bonded seal	1	G 1/2" - FPM					
5e	O-Ring	1	O-R 2050 Øi 12.42 x 1.78 - FPM					
5f	Bp or No Bp O-Ring	1	OR 121 Ø 15.88 x 2.62	OR 3087 (NBR 90 Sh A) Ø 21.89 x 2.62	OR 3143 (NBR 90 Sh A) Ø 36.14 x 2.62			
5g	Bp or No Bp O-Ring	1	OR 2031 Ø 7.65 x 1.78	OR 2037 Ø 9.25 x 1.78	OR 2081 Ø 20.35 x 1.78			
5h	Protective seal	1	01026521	01026509	01026510			
5m	Drain plug	1					G 3/8" with seal	
-	Indicators	1	See order table					
6	Indicator connection plug	1	T2					

Ordering information FHP

Filter assembly **FHP**

Example: FHP

1	2	3	4	5	6	7	8 a
<input type="checkbox"/>	<input type="checkbox"/>	<input type="checkbox"/>	<input type="checkbox"/>	<input type="checkbox"/>	<input type="checkbox"/>	<input type="checkbox"/>	<input type="checkbox"/>
135	1	S	A	G1	A03	H	P01

Filter element **HP**

Example: HP

1	2	6	7	8 b
<input type="checkbox"/>	<input type="checkbox"/>	<input type="checkbox"/>	<input type="checkbox"/>	<input type="checkbox"/>
135	1	A03	H	P01

1 - Size

- 065
- 135
- 320
- 321

2 - Filter length

- 1
- 2
- 3
- 4 (only for FHP 320-321)

3 - Valves

- S** Without bypass
 - B** With bypass
 - D** With bypass + check valve*
 - V** With Reverse Flow* (only for FHP 320)
 - Z** With Reverse Flow + bypass (only for FHP 320)
 - T** Without bypass + check valve*
- *Reduced cross-section oilways

4 - Seals

- A** NBR
- V** FPM

6 - Filter elements

- A03** Inorganic microfibre 3 µ
 - A06** Inorganic microfibre 6 µ
 - A10** Inorganic microfibre 10 µ
 - A16** Inorganic microfibre 16 µ
 - A25** Inorganic microfibre 25 µ
 - M25** Stainless steel mesh 25 µ (style N only)
- } βx (c) ≥ 1000
See page 9

7 - Filter elements differential pressure

- N** 20 bar
- H** 210 bar
- R** (Filter with Reverse Flow + bypass)
- S** (Filter with Reverse Flow)

8 - Options

a) Filter

- P01** MP Standard filters
- P02** Maintenance from base of housing (FHP 320 - 4 only)
- Pxx** Customer request

b) Filter element

- P01** MP Filtri standard
- Pxx** Customer request

5 - Connections

Type	065	135	320	321
<input type="checkbox"/> G1	G 1/2"	G 3/4"	G 1 1/4"	G 1 1/4"
<input type="checkbox"/> G2	G 3/4"	G 1"	G 1 1/2"	G 1 1/2"
<input type="checkbox"/> G3	1/2" NPT	3/4" NPT	1 1/4" NPT	1 1/4" NPT
<input type="checkbox"/> G4	3/4" NPT	1" NPT	1 1/2" NPT	1 1/2" NPT
<input type="checkbox"/> G5	SAE 8	SAE 12	SAE 20	SAE 20
<input type="checkbox"/> G6	SAE 12	SAE 16	SAE 24	SAE 24
<input type="checkbox"/> F1	-	3/4" SAE 3000 PSI/M	1 1/4" SAE 3000 PSI/M	-
<input type="checkbox"/> F2	-	1" SAE 3000 PSI/M	1 1/2" SAE 3000 PSI/M	-
<input type="checkbox"/> F3	-	3/4" SAE 3000 PSI/UNC	1 1/4" SAE 3000 PSI/UNC	-
<input type="checkbox"/> F4	-	1" SAE 3000 PSI/UNC	1 1/2" SAE 3000 PSI/UNC	-
<input type="checkbox"/> F5	-	3/4" SAE 6000 PSI/M	1 1/4" SAE 6000 PSI/M	-
<input type="checkbox"/> F6	-	3/4" SAE 6000 PSI/UNC	1 1/4" SAE 6000 PSI/UNC	-

DIFFERENTIAL INDICATORS
(see page 15)

MP Filtri - The filter functions as described in this bulletin are valid exclusively for original MP Filtri filter elements and replacement parts. All rights reserved

The data in this publication are purely guideline. MP Filtri reserves the right to make changes to the models described herein at any time it deems fit in relation to technical or commercial requirements. The colours of the products shown on the cover are purely guideline. Copyright. All rights reserved.

Description

The filter elements are available with surface and depth filtration media.

Surface media are made of stainless steel wire mesh, nominal filtration.

Depth filtration media are made of inorganic fibre impregnated with epoxy resins, absolute filtration.

Differential collapse pressure

Mesh M Δp 20 bar Series N

Mesh T Δp 210 bar Series H

Mesh A Δp 20 bar Series N

Fibre A Δp 20 bar Series R

Fibre A Δp 210 bar Series H

Fibre A Δp 210 bar Series S

Elements with Δp value of 20 bar are utilised in filters with bypass valves.

Elements with Δp value of 210 bar are utilised in filters without bypass valves.

The use of filter elements with Δp value of 20 bar is permitted in filters without bypass valves exclusively during the system start-up phase.

Elements types R and S must be utilised when the filters are equipped with Reverse Flow valves, with or without bypass valve.

Materials

Support tubes - steel with heat-chemical treatment.

Inner support tube - steel with heat-chemical treatment.

Compatibility with fluids, filter elements series N-R-H-S

- The filter elements are compatible with:
 - Mineral oils to ISO 2943 - 4
 - Aqueous emulsions
 - Synthetic fluids, water glycol.
- Seals, standard in NBR compatible with:
 - Mineral oils to ISO 2943 - 4
 - Aqueous emulsions
 - Synthetic fluids, water glycol.
- FPM seals compatible with:
 - Synthetic fluids type HS-HFDR-HFDS-HFDU
 - To ISO 6743-4.

Composition of filtration media

Series: mesh N

Internal support mesh, stainless steel filtration mesh, external support mesh.

Series: fibre N

Internal support mesh, filter media support, filtration media, prefilter media, external support mesh.

Series: fibre R

Internal support mesh, filtration media support, filtration media, prefilter media, external support mesh, external support tube (stainless steel).

Series: fibre H

Stainless steel support tube, stainless steel internal support mesh, filtration media support, filtration media, prefilter media, external support mesh.

Series: fibre S

Stainless steel support tube, stainless steel internal support mesh, filtration media support, filtration media, prefilter media, external support mesh, stainless steel external support tube.

Series: mesh H

Stainless steel support tube, stainless steel internal support mesh, filtration media, stainless steel filtration mesh, external support mesh.

Reference standards

All filter elements comply with the following ISO standards

ISO 2941 - Collapse and burst resistance.

ISO 2942 - Bubble point test resistance.

ISO 2943 - Compatibility with fluids.

ISO 3723 - Resistance to axial deformation.

ISO 3724 - Fatigue test with flow.

ISO 3968 - Pressure drop.

ISO 16889 - Filtration efficiency by means of Multipass.

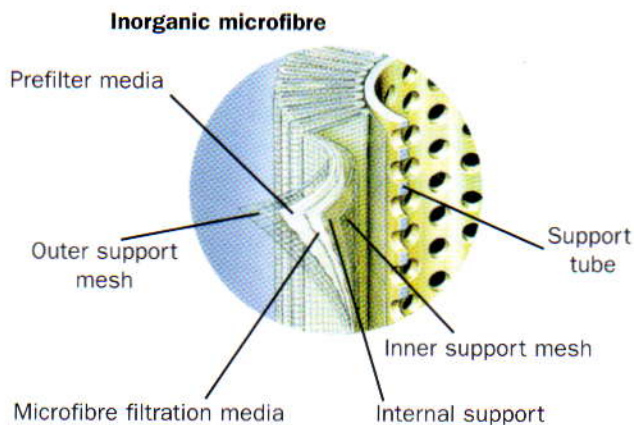

**Multipass test
in compliance with new ISO 16889 standard.
Contaminant ISO MTD**

Value β	2	10	75	100	200	1000
Filtration efficiency in %	50%	90%	98.70%	99%	99.50%	99.90%

**Multipass test
in compliance with original ISO 4572
standard.
Contaminant ACFTD**

Value β	200
Filtration efficiency in %	99.50%

Filter element	(µm ©)						µm	
A03	<3	<3	<3	<3	3.30	4.2	A03 3 µm	3
A06	<3	<3	4.31	4.53	5.07	6.3	A06 6 µm	6
A10	<6	<6	6.12	6.41	7.12	9.0	A10 10 µm	10
A16	<7	<7	10.45	10.97	12.13	13.9	A16 16 µm	16
A25	<9	12.34	15.82	16.30	17.46	19.3	A25 25 µm	25

The above data are referred to a final Δp value of 16 bar

Characteristics of filter elements with nominal filtration, M / T series

For the square stainless steel wire mesh filtration degree is defined as the maximum diameter of a sphere corresponding to the mesh size, in microns.

International standards for fluid contamination control

Components	Recommended filtration								
	12/10/7	13/11/8	14/12/9	15/13/10	16/14/11	17/15/12	18/16/13	19/17/14	20/18/15
Servo valves			●	●	●				
Proportional Valves				●	●	●			
Variable displacement Pumps					●	●	●		
Cartridge valves						●	●	●	
Piston pumps						●	●	●	
Vane pumps							●	●	●
Pressure / flow rate control valves							●	●	●
Solenoid valves							●	●	●
ISO code	12/10/7	13/11/8	14/12/9	15/13/10	16/14/11	17/15/12	18/16/13	19/17/14	20/18/15
NAS code	1	2	3	4	5	6	7	8	9
Absolute filtration recommended	3 micron			6 micron			10 micron		>10

Microfibre filter elements tested in collaboration with the following independent institutes.

Institute of Filtration
(France)



I.F.T.S.

Filter sizing

Correct sizing of the filter, having in-line or manifold connections must be based on a total pressure drop of between 0.8 and 1.5 bar.

For styles with reverse flow valves, reversible flow, and duplex filters, the total pressure drop can be between 1.5 and 3 bar.

The pressure drop calculation is performed by adding together the value for the housing and the value for the filter element.

The pressure drop in the housing is proportional to the fluid density kg/dm^3 , all the graphs in the catalogue are referred to mineral oil with density of 0.86 kg/dm^3 .

The filter element pressure drop value is proportional to viscosity mm^2/s (cSt), the Y values in the catalogue are referred to viscosity of $30 \text{ mm}^2/\text{s}$ (cSt).

Sizing

Δp Total

Δp_c Filter body

Δp_e Filter element

Y Multiplication factor (see pages 13 to 14)

Q l/min = flow rate

V1 = reference viscosity $30 \text{ mm}^2/\text{s}$ (cSt)

V2 = operating viscosity in mm^2/s

$\Delta p_{\text{Tot.}} = \Delta p_c + \Delta p_e$

$\Delta p_e = Y : 1000 \times Q \times (V_2/V_1)$

Calculation example with HLP fluid

Variation in viscosity

Data:

Filter with in-line connections

Pressure = 380 bar

Flow rate = 150 l/min

Viscosity = $46 \text{ mm}^2/\text{s}$ (cSt)

Density = 0.86 kg/dm^3

Filtration = 10μ absolute

With bypass valve

Filter type - FHP 135 3 (see bodies pressure drop graphs on page 57)

Practical example

Q = 150 l/min

V2 = $46 \text{ mm}^2/\text{s}$

Pmax = 380 bar

Filtration = 10μ absolute

$\Delta p_{\text{Tot. max}} = 1.5 \text{ bar}$ (max. recommended value)

Filter element series N, Δp max 20 bar

$\Delta p_c = 0.657 \text{ bar}$ (* see diagram)

$\Delta p_e = (3.38 : 1000) \times 150 \times (46/30) = 0.777 \text{ bar}$

$\Delta p_{\text{Tot.}} = 0.657 + 0.777 = 1.434 \text{ bar}$

Sized filter type:

FHP 135 3 S A G2 A10 N P01

Calculation examples with HFD fluid

Variations in viscosity and density

Data:

Filter with in-line connections

Pressure = 380 bar

Flow rate = 150 l/min

Viscosity = $46 \text{ mm}^2/\text{s}$ (cSt)

Density = 1.1 kg/dm^3

Filtration = 10μ absolute

With bypass valve

Filter type - FHP 135 3 (see bodies pressure drop graphs on page 57)

Practical example

Q = 150 l/min

V2 = $46 \text{ mm}^2/\text{s}$

Pmax = 380 bar

Filtration = 10μ absolute

$\Delta p_{\text{Tot. max}} = 1.5 \text{ bar}$ (max. recommended value)

Filter element N series, Δp max 20 bar

$\Delta p_c = 0.657 \times (1.1/0.86) = 0.84$

$\Delta p_e = (3.38 : 1000) \times 150 \times (46/30) = 0.777 \text{ bar}$

$\Delta p_{\text{Tot.}} = 0.84 + 0.777 = 1.62 \text{ bar}$

Filter type:

FHP 135 3 S A G2 A10 N P01 (Δp max exceeded)

Switch to next size up **FHP 320...**

Pressure drops Δp Body

The curves are plotted using mineral oil with density of 0.86 kg/dm^3 to ISO 3968.

Δp varies proportional with density.

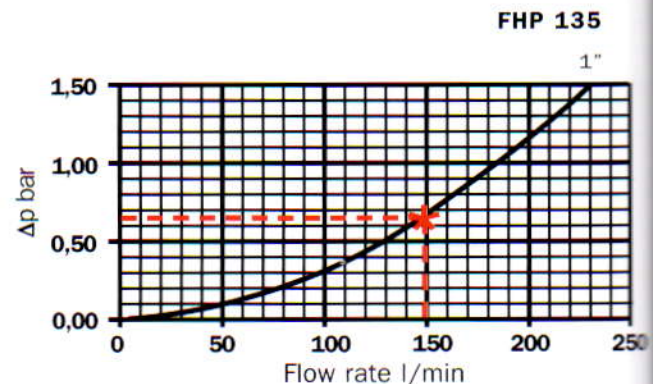

For Y values see next page:

Filter Element	Series N - R					Series N
	Filtration					
Type	A 0 3	A 0 6	A 1 0	A 1 6	A 2 5	M 2 5
HP 037 1	70,66	53,20	25,77	20,57	14,67	0,497
2	26,57	23,27	12,46	09,88	05,58	0,286
5	36,57	32,28	18,00	13,38	08,00	0,286
HP 050 1	31,75	33,00	13,16	12,33	07,29	01,60
2	24,25	21,26	11,70	09,09	04,90	01,40
3	17,37	16,25	08,90	07,18	03,63	01,25
4	12,12	10,75	06,10	05,75	03,08	01,07
5	07,00	06,56	03,60	03,10	02,25	00,80
HP 065 1	58,50	43,46	26,66	19,66	10,71	01,28
2	42,60	25,64	17,66	13,88	07,32	01,11
3	20,50	15,88	08,18	06,81	03,91	00,58
HP 135 1	20,33	18,80	09,71	08,66	04,78	02,78
2	11,14	10,16	06,60	06,38	02,22	01,11
3	06,48	06,33	03,38	03,16	02,14	01,01
HP 320 1	10,88	09,73	05,02	03,73	02,54	01,04
2	04,40	03,83	01,75	01,48	00,88	00,71
3	02,75	02,11	01,05	00,87	00,77	00,61
4	02,12	01,77	00,98	00,78	00,55	00,47
HP 500 1	05,04	04,12	02,80	03,20	02,20	0,15
2	03,80	03,05	02,33	02,23	01,83	0,10
3	02,86	02,80	02,06	02,00	01,91	0,075
4	01,81	01,33	00,94	00,94	00,71	0,050
5	01,33	01,15	00,80	00,67	00,64	0,040

HP series filter elements

Multiplication factor "Y" for definition of the pressure drop of filter elements.

Reference viscosity 30 mm²/s

Filter Element	Series N					Series N
	Filtration					
Type	A 0 3	A 0 6	A 1 0	A 1 6	A 2 5	M 2 5
HF 320 1	03,65	02,95	02,80	01,80	00,90	-
2	02,03	01,73	01,61	01,35	00,85	-
3	01,84	01,42	01,42	01,22	00,80	-

HF series filter elements

Multiplication factor "Y" for definition of the pressure drop of filter elements.

Reference viscosity 30 mm²/s

Filter Element	Serie H - S					Serie H
	Filtration					
Type	A 0 3	A 0 6	A 1 0	A 1 6	A 2 5	T 1 0
HP 020 0	216,2	162,5	72,72	58,04	36,36	
1	108,1	81,25	36,36	29,02	18,18	*
HP 050 1	47,33	34,25	21,50	20,50	14,71	
2	29,10	25,95	14,04	10,90	05,88	
3	20,85	19,50	10,68	08,61	04,36	*
4	14,55	12,90	07,32	06,90	03,69	
5	09,86	09,34	06,40	04,80	02,50	
HP 065 1	62,28	58,56	26,66	21,66	12,42	
2	43,30	36,63	17,66	14,44	08,88	*
3	20,55	16,90	08,55	07,09	04,16	
HP 135 1	29,16	25,33	13,00	12,47	05,92	
2	14,28	11,04	07,86	07,60	04,44	*
3	08,96	07,46	04,89	04,16	03,07	
HP 320 1	13,00	12,19	06,80	06,40	03,32	
2	06,45	05,31	03,01	02,89	01,73	
3	04,13	03,14	01,90	01,78	01,17	*
4	03,17	02,71	01,80	01,70	01,10	
HP 500 1	10,53	08,95	04,88	05,00	03,28	
2	05,84	05,04	03,16	03,05	02,52	
3	04,35	04,24	04,60	02,48	02,37	*
4	03,10	02,48	01,56	01,53	01,02	
5	01,93	01,83	01,14	01,08	00,69	

HP series filter elements

Multiplication factor "Y" for determination of the pressure drop of filter elements.

Reference viscosity 30 mm²/s

* "Y" values supplied on request

Filter Element	Serie H					Serie N
	Filtration					
Type	A 0 3	A 0 6	A 1 0	A 1 6	A 2 5	T 1 0
HF 320 1	06,50	06,20	03,95	03,32	02,70	
2	03,17	02,87	02,23	02,02	01,65	*
3	02,60	02,40	01,64	01,62	01,42	

HF series filter elements

Multiplication factor "Y" for determination of the pressure drop of filter elements.

Reference viscosity 30 mm²/s

* "Y" values supplied on request