

EF Series

DRUM / BARREL PUMPS

Performance

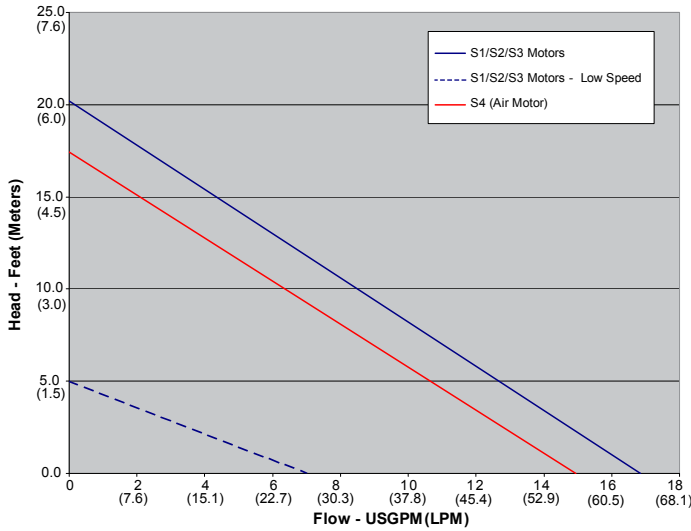

Viscosity	100 cP	200 cP	300 cP
Max. Flow	7 gpm 27 lpm	5 gpm 19 lpm	3.7 gpm 14 lpm
Max. Head	16 feet (4.9 m)		

Note: All testing was performed with water at 68°F. Actual performance can vary by +/- 10%. Actual performance will decrease with increased fluid viscosity and specific gravity. Viscosity and performance are based on electric motor at high speed.



Medium performance, light viscosity sealless drum/barrel pumps for container-to-container transfer of acids, corrosives and chemicals.

FEATURES

- Sealless
- Polypropylene, pure PP/PVDF or 316SS tubes
- Dual speed adjustable motors
- Interchangeable motors and tubes
- Lightweight
- Economical
- Built-in hose and cord clips - EFP and EFV only



PERFORMANCE

- 1.2 SG
- 300 cP maximum
- Max. temperatures: EFP – 150°F (66° C)
EFV – 160°F (71° C)
EFS – 212°F (100° C)

ELECTRIC – 50/60 HZ	AIR
• 17 gpm (64.4 lpm)	• 15 gpm (56.8 lpm)
• 20 feet TDH (6.1 m)	• 17 feet TDH (5.2 m)

Tube Specifications

Model	Tube Material	Tube Sizes				Seal	Shaft	Internals	Hose Size	
		Diameter		Length					in	mm
		in	mm	in	cm					
EFP	Polypropylene	1 1/4	31.8	16	41	Sealless	316 SS	FKM, PTFE	3/4	20
EFV	Pure PP/PVDF			27	69		Alloy 625			
EFS	316SS			40	102		316 SS			
				48	122					

Motor Specifications

Model	Type	Certifications	Power Requirements	Input	RPM
S1	Splashproof, ENC3, Double Insulated	CSA	115VAC/60 Hz	1/3 Hp, 230 W	8,000 / 14,000
S2	Splashproof, IP24, Double Insulated	CE	230VAC/50-60 Hz	250 W	8,000 / 14,000
S3	Splashproof, IP24, Double Insulated	CE	115VAC/50-60 Hz	230 W	8,000 / 14,000
S4	Air*	CE	40 psi @ 27 cfm	1/2 Hp	300 - 11,000

Note: When pumping flammables or combustibles, use an air motor on a stainless steel tube with a static protection kit.

*An air motor is a non-electrical device, which means the possibility of explosion from igniting flammables or combustibles is reduced. Air motor performance will depend upon user's compressor and system set up.



Dimensions

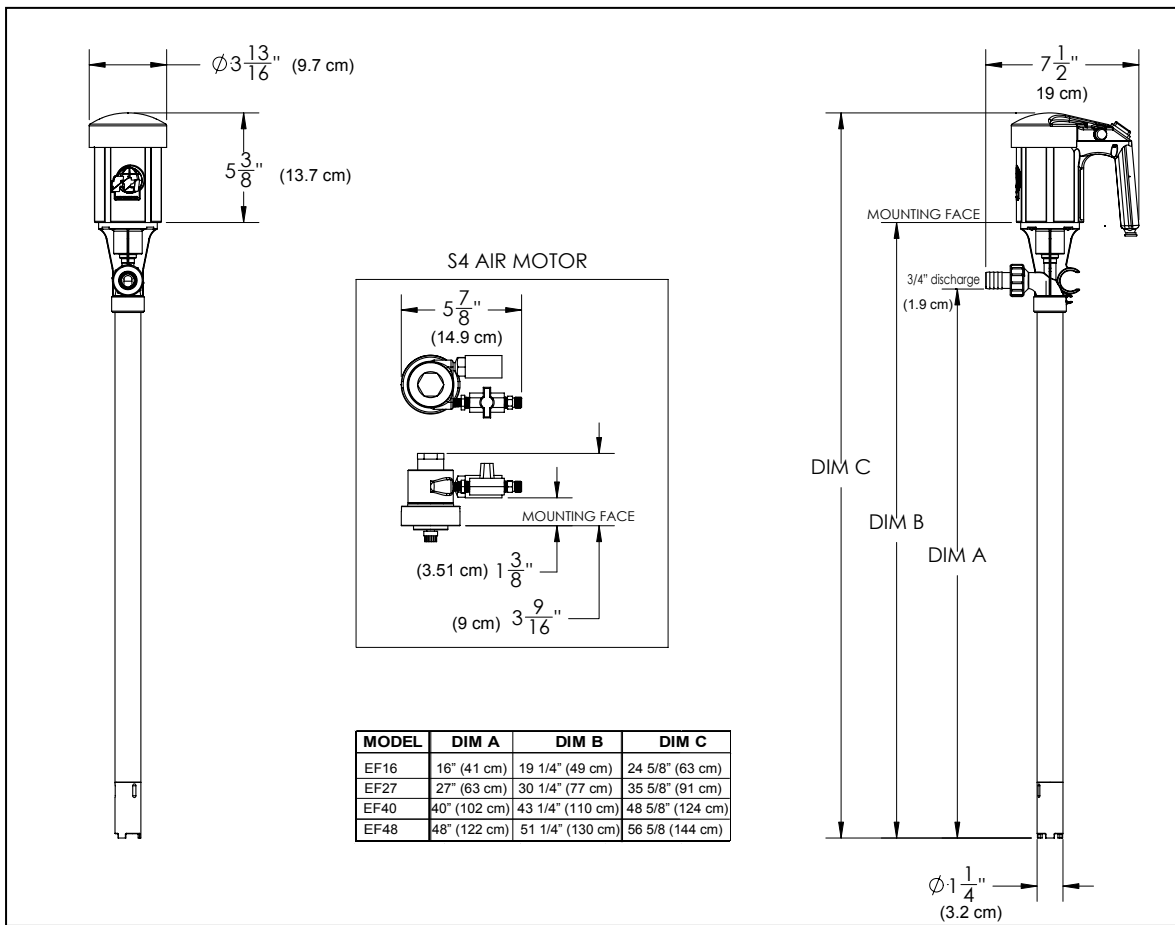

Accessories



Dispensing Nozzle
Stainless steel /FKM nozzle with
3/4" hose barb - P/N 107231

Dispensing Nozzle
Polypropylene/316SS nozzle with
3/4" hose barb - P/N A101497-1



Discharge Hose -
Reinforced PVC, 5 ft. length,
3/4" ID x 1" OD, P/N 107435

EPDM hose, 8 ft. length, 3/4" ID
x 1.13" OD, P/N 107446



Bung Adapter
Stainless Steel, P/N 107426

Bung Adapter -
Polypropylene, P/N 107425



Static Protection Kit - includes 4 ft.
synthetic rubber cross-linked poly-
ethylene grounded hose with brass
fittings with 3/4" MNPT, ground wire,
and clamps - P/N 107429



FINISH THOMPSON INC.

921 Greengarden Road • Erie, PA 16501-1591 U.S.A.
Ph 814-455-4478 • Fax 814-455-8518
Email fti@finishthompson.com • www.finishthompson.com
U.S. & Canada 1-800-934-9384