

Single Banjo Coupling with Steel Bolt, Imperial

Wade



Features & Benefits

- The construction incorporates a brass body and a steel bolt for additional strength
- The design enables connection of tube at 90° to the BSP parallel male stud thread
- The banjo coupling allows rotational adjustment. During installation, (before fully tightening the hexagon head on the banjo bolt), the tube outlet (compression end) can be aligned in any direction within a 360° turning circle. This provides a distinct advantage over a standard BSP parallel male stud elbow which does not allow the same degree of adjustment
- Banjo couplings are commonly used on automotive fuel, oil and hydraulic applications such as brake and clutch systems

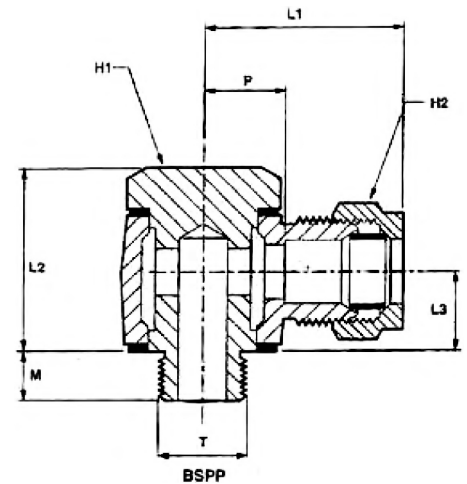

Part No	Tube OD	T BSPP Male Thread	M Stud Length	L1 Length	L2 Length	L3 Length	H1 Hex A/F	H2 Hex A/F	P Abutment
WADE-3503	1/4"	1/4"	0.343"	1.062"	0.968"	0.421"	0.71"	0.601"	0.5"
WADE-6505/1	5/16"	1/8"	0.312"	1.062"	0.968"	0.421"	0.71"	0.601"	0.5"
WADE-3505	5/16"	1/4"	0.343"	1.062"	0.968"	0.421"	0.71"	0.601"	0.5"