



s.84 Potable Water 1/4"-2" Hot Forged Brass Ball Valves



Legionella is a bacterium that lives and proliferates in natural and artificial aquatic environments, at temperatures ranging between 5.7°C and 55°C, and standing up to acidic and alkaline environments. New s.84W is approved for use with drinking water; the specific ball design avoids water stagnation and the spread of bacteria in the system.

Quality

- 24 hour 100% seal test guaranteed
- Dual sealing system allows valve to be operated in either direction, making installation easier
- No metal-to-metal moving parts
- No maintenance ever required
- Handle clearly shows ball position
- Silicone-free lubricant on all seals
- Travel stops on body to avoid stresses at stem
- Chrome-plated brass ball for longer life with rinse hole

Body

- Hot forged, sand blasted, external nickel-plated brass body and cap sealed with Loctite® or equivalent thread sealant
- Finest brass according to EN 12165 and EN 12164 (formerly DIN 17660 and UNI 5705-65) specifications

Stem

- Blowout-proof nickel plated brass stem
- Two EPDM O-Rings at the stem for maximum safety

Seals

- Pure PTFE self-lubricating seats with flexible lip design

PED Directives

- According to 97/23 CE module A: it cannot be used with dangerous gases in sizes larger than 25mm

Threads

- EN 10226-1 parallel female by female threads

Flow

- Full port to DIN 3357 for maximum flow

Handle

- Geomet® carbon steel handle with thick PVC dip coating; handle coating offers both thermal and electrical protection

Working Pressure

- 40 bar (600 psi)
- Non-shock cold working pressure
- DIN-EN 13828 limitations for potable water: 10 bar (kg/cm²) non-shock cold working pressure and +65°C temperature (occasional excursions up to +90°C are permitted for a period of one hour maximum)

Working Temperature

- -40°C (-40°F) to +150°C (+302°F)
- Warning: freezing of the fluid in the installation may severely damage the valve

Options

- T-handle
- Patented locking device
- Taper male by parallel female threads

Upon Request

- Glass filled PTFE seals
- Custom design
- Stem extension
- AISI 430 stainless steel handle
- Special configuration for industrial oxygen application

Approved by or in compliance with:

- DVGW (Deutschland)
- GOST-R (Russia)
- Hygiene and Epidemic Centre in Moscow city (Russia)
- Attestation de Conformité Sanitaire (France)
- RoHS Compliant
- EAC – Declaration of conformity (Russia-Kazakhstan-Belarus)



NOTE: Approvals apply to specific configurations/sizes only.

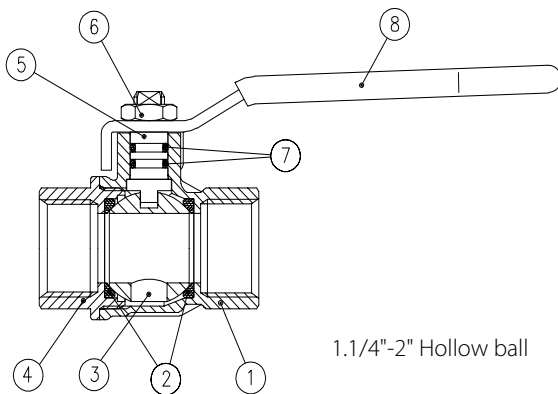

Part Description	Q.ty	Material
1 Nickel plated body (external treatment)	1	CW617N
2 Seat	2	PTFE
3 Chrome plated ball with rinse hole (read rinse hole on sizes from 3/4" up to 2")	1	CW617N
4 Nickel plated end cap (external treatment)	1	CW617N
5 Nickel plated stem O-ring design	1	CW617N
6 Geomet® nut	1	CB4FF
7 O-Ring	2	EPDM
8 Green PVC coated Geomet® steel handle	1	DD11

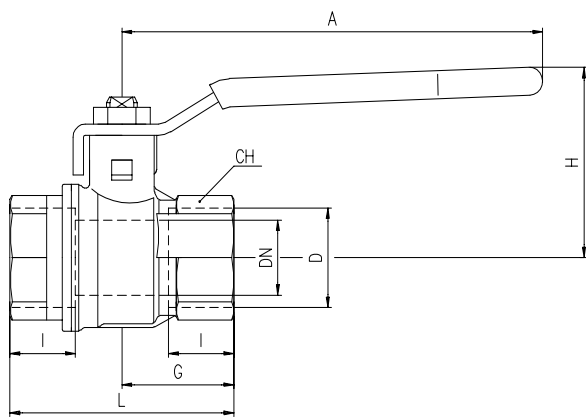

Code	S84B00W	S84C00W	S84D00W	S84E00W	S84F00W	S84G00W	S84H00W	S84I00W
D (Inch)	1/4	3/8	1/2	3/4	1	1 1/4	1 1/2	2
DN (mm.)	8	10	15	20	25	32	40	50
I (mm.)	12	12	15.5	17	21	23	23	26.5
L (mm.)	45	45	59	64	81	93	102	121
G (mm.)	22.5	22.5	29.5	32	40.5	46.5	51	60.5
A (mm.)	82	82	100	120	120	158	158	158
H (mm.)	38	38	43	50	54	73	79	86
CH (mm.)	20	20	25	31	40	49	54	68.5

DN shows the nominal flow diameter. Actual flow diameter complies with full port DIN 3357 part 4.

Ask for additional information on the whole range of **RuB** valves and consult with your supplier for special applications. Ball valves are marked CE on handle from 1.1/4" to 2" as follow: CE XXCODEXX Cat I-A

Pressure-Temperature Chart

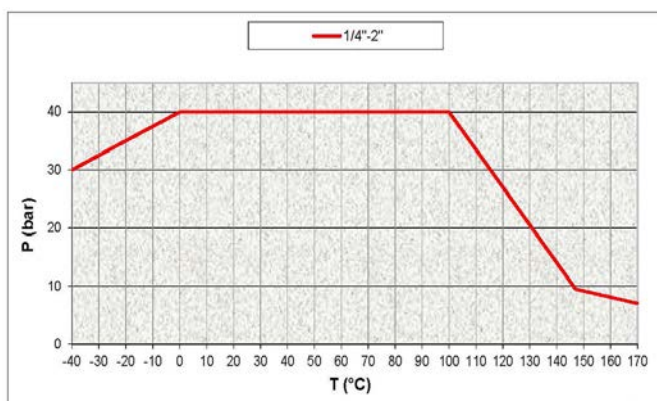

Pressure Drop Chart

