

Airmatic® Lubricator

Pneumatic Operation, Oil



General

The Airmatic lubricator is a simple economical unit with a broad range of output. It is designed to be operated with shop air. The stroke setting is easily adjusted to suit a wide variety of industrial centralized lubrication needs. The package can be supplied with either a 1, 4 or 12 liter reservoir.

Application

The Airmatic lubricator is for use with cyclic oil lubrication systems. The unit can be used with single line resistance (SLR), positive displacement injector (PDI), progressive distribution and injector systems.*

Operation

Airmatic® lubricator includes an air actuated, spring return piston pump with an adjustable output between 2 to 10cc for each piston stroke at discharge pressures up to 500 psi. Oil output is related to piston travel and cycles per unit time. Stroke movement is preset to a discharge and supply air pressure governs the output delivery pressure. When used with positive displacement injectors, a built-in pressure relief device lets the PDI reset after discharge.

For extended service, incoming air must be dry. Always use a suitable FRL unit (filter/regulator/lubricator) to control air to recommended operating range. Normally, the air-operated Airmatic is used with a 3/2-way electrical solenoid valve (optional) to control and vent shop air from the pump air inlet. All models are available with optional 3/2-way valve.

To adjust lubricant delivery, loosen locknut on hex socket adjusting screw (see Figure 1 on right). Turn delivery adjusting screw clockwise to reduce discharge - use graduated label as guide, set to desired setting and tighten locknut (insert shows setting at 8cc). For PDI systems, maximum discharge of 10cc/stroke is recommended.



*Refer to appropriate engineering manuals for normal system limitations when sizing distribution proportioning devices for use at a particular discharge setting.

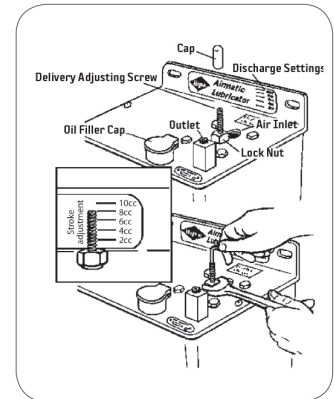

Figure 1:
Lubricant Delivery Adjustment

Technical Data

Delivery Volume	2cc-10cc/actuation cycle (infinite adjustment)
Viscosity Range	150-8000 SSU ¹
Normal Range Cycle	Up to 30 cycles/minute maximum ²
Operating Temperature	32°F to 120°F (0°C to 49°C)
Oil Outlet Connection	1/8" NPTF (female)
Low Level Switch	0.17 amp at 110 VAC
Solenoid Valve	0.12 amp at 110 VAC
Lubricator Air Connection (without solenoid)	1/4" NPTF (female)
Operating Pressure	300 psi (21 bar) - SLR & PRG 400 psi (28 bar) - PDI & INJ
Recommended Incoming Air Pressure	80 psi (5 bar) - SLR & PRG 100 psi (7 bar) - PDI & INJ
Air/oil Pressure Ratio	1:4
Maximum Inlet Pressure	125 psi
Minimum Inlet Pressure	70 psi

¹ Viscosity range at operating temperature may be restricted by internal relief valve (consult Bijur Delimon).

² System parameters may affect this rate (consult Bijur Delimon).



System Design

If the distribution system incorporates extensive use of flexible lines, a slightly larger discharge must be used to compensate for the resiliency of the flexible connections. Solve for the following "R" value and ADD this amount to the required pump discharge:

- + R = .030 x feet of 5/16" O.D. flexible hose
- + R = .035 x feet of 7/16" O.D. flexible hose

How to Order

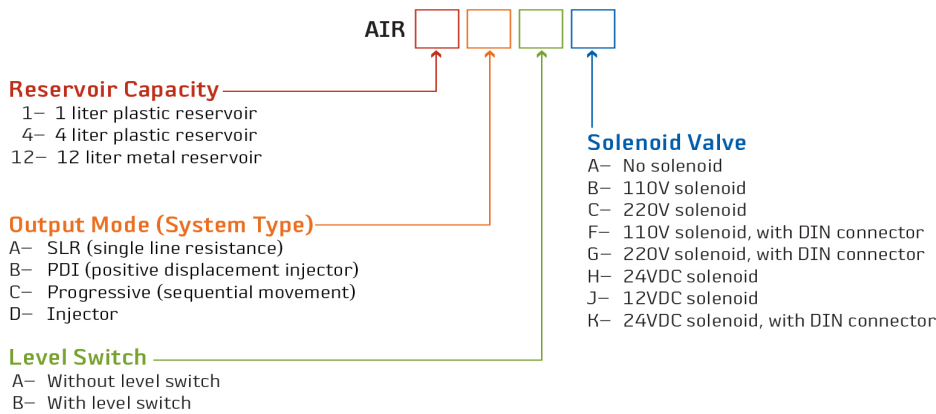

*NOTE:

System type "D" is for type ZEE injectors

Example: 1 liter unit for SLR system without switch and solenoid, use Part #AIR1AAA.
 12 liter unit for SLR system without switch and solenoid, use Part #AIR12AAA.

Several options are available in this configuration. It is necessary to choose the proper prefix letters for the particular type of unit required. Designation of lubricator is **AIR**, followed by a four part code, specifying reservoir size and pump options required.

After the letters **AIR**, insert code for **reservoir capacity**. The third letter designation identifies the lubricator to be used for **output mode (system type)**. Select the correct designation for lubricator unit to service the appropriate distribution system. Specify whether a low oil **level switch** is required by designating appropriate letter code in the fourth letter designation. **Solenoid valve** selection is last designation. If required, select prefix for solenoid valve by voltage.



Service Parts- 1 Liter Model

Item	Part #	Description
1	B10812-2	Cap
2	B8197	Gasket
3	HF705C	Cap
4	19030	Strainer
5	D3218	Reservoir assembly
6	B7760-5	Level switch (closes at low level)
7	20034	Retainer
8	20252-1	Nut (4x)
9	A3841	Support (*)
10	A3848	Screen (*)
11	A3899	Ring (*)
12	A3843	Clamp (*)
13	B3907	Check valve
14	B6086	Adapter
15	19700-7	Tubing
16	19700-7	Tubing assembly
17	20736-1	Valve assembly**
18	20311-1	Solenoid valve 110 VAC
	20311-2	Solenoid valve 220 VAC
	20311-3	Solenoid valve 110 VAC w/DIN conn.
	20311-4	Solenoid valve 220 VAC w/DIN conn.
	20311-5	Solenoid valve 24 VDC
	20311-6	Solenoid valve 12 VDC
	20311-7	Solenoid valve 24 VDC w/DIN Conn
19	A4239-M	Muffler filter

* = Available in Kit #A0293

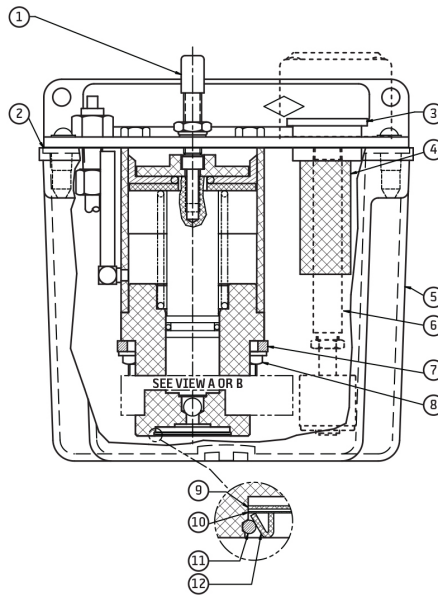

VIEW A - SLR & PROGRESSIVE MODELS

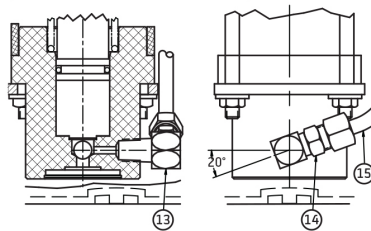

VIEW B - PDI MODELS & INJ MODELS

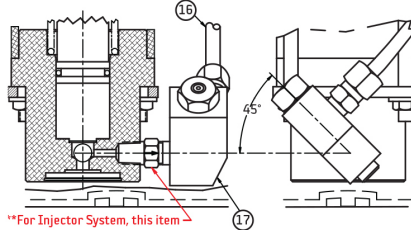

VIEW C - SOLENOID VALVE

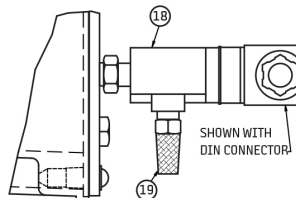



Service Parts- 4 Liter Model

Item	Part #	Description
1	20663-6KIT	Reservoir assembly ¹
2		(Reservoir, gasket, & screws)
3	B10812-2	Cover
4	HF705C	Cap
5	19030	Strainer
6	A3841	Support (*)
7	A3848	Screen (*)
8	A3899	Ring (*)
9	A3843	Clamp (*)
10	B3907	Check Valve
11	20736	Quick dump valve assembly**
12	20311-1	Solenoid valve 110 VAC
	20311-2	Solenoid valve 220 VAC
	20311-3	Solenoid valve 110 VAC w/DIN conn.
	20311-4	Solenoid valve 220 VAC w/DIN conn.
	20311-5	Solenoid valve 24 VDC
	20311-6	Solenoid valve 12 VDC
	20311-7	Solenoid valve 24 VDC w/DIN conn.
13	A4239-M	Muffler filter

* = Available in Kit #A0293
¹ = See note on reservoir

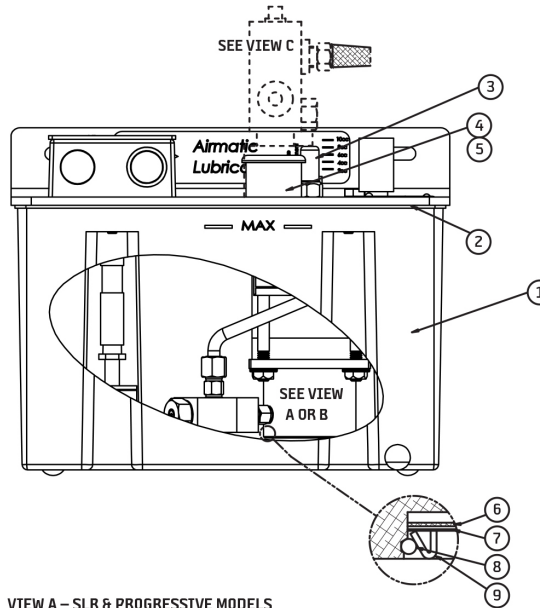

VIEW A – SLR & PROGRESSIVE MODELS

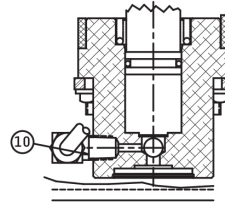

VIEW B – PDI MODELS & INJ MODELS

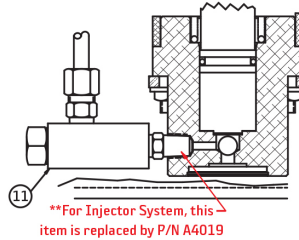

VIEW C – SOLENOID VALVE

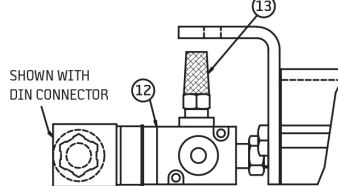

RESERVOIR NOTE:
 4 Liter Airmatic Pumps with a date code previous to "VW" used 2 mounting screw design reservoir; Reservoir p.n. D3845/Gasket B10670

New design is a 4 mounting screw reservoir; p.n. 20663-6KIT as shown in the service part list to the left.



Service Parts- 12 Liter Model

Item	Part #	Description
1	B9842	Filler cap
2	17661	Strainer
3	B10812-2	Cover
4	19312	Sight gauge
5	B9602	Plug
6	H0413	O-ring
7	19846-2	Reservoir
8	A3841	Support (*)
9	A3848	Screen (*)
10	A3899	Ring (*)
11	A3843	Clamp (*)

12	B3907	Check valve
13	20736	Quick dump valve assembly**
14	20311-1	Solenoid valve 110 VAC
	20311-2	Solenoid valve 220 VAC
	20311-3	Solenoid valve 110 VAC w/DIN conn.
	20311-4	Solenoid valve 220 VAC w/DIN conn.
	20311-5	Solenoid valve 24 VDC
	20311-6	Solenoid valve 12 VDC
	20311-7	Solenoid valve 24 VDC w/DIN conn.
15	A4239-M	Muffler filter

* = Available in Kit #A0293

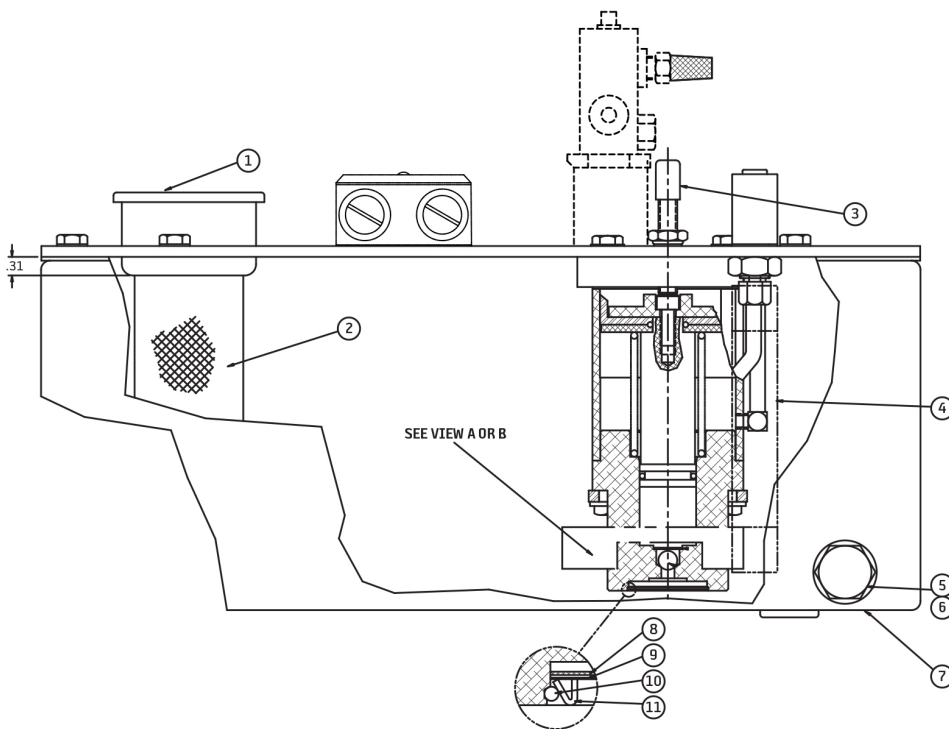

VIEW A – SLR & PROGRESSIVE MODELS

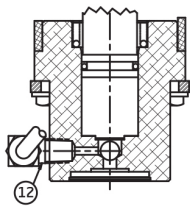

VIEW B – PDI MODELS & INJ MODELS

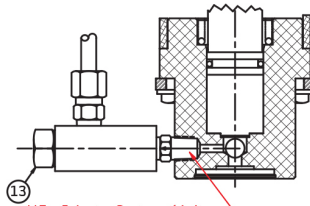

VIEW C – SOLENOID VALVE

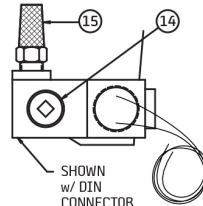



Dimensional Schematics

Measurements shown in inches.

1 Liter Model (PDI Version Shown)

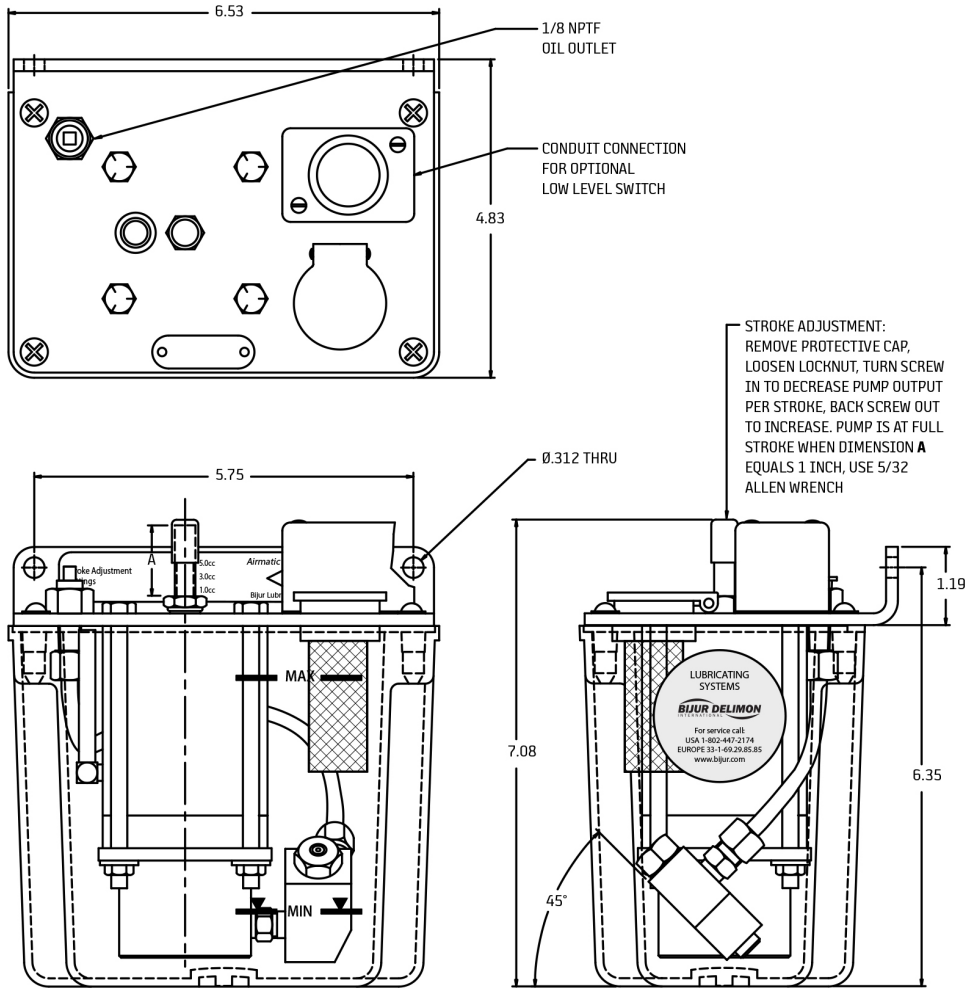



Dimensional Schematics

4 Liter Model

Measurements shown in inches.

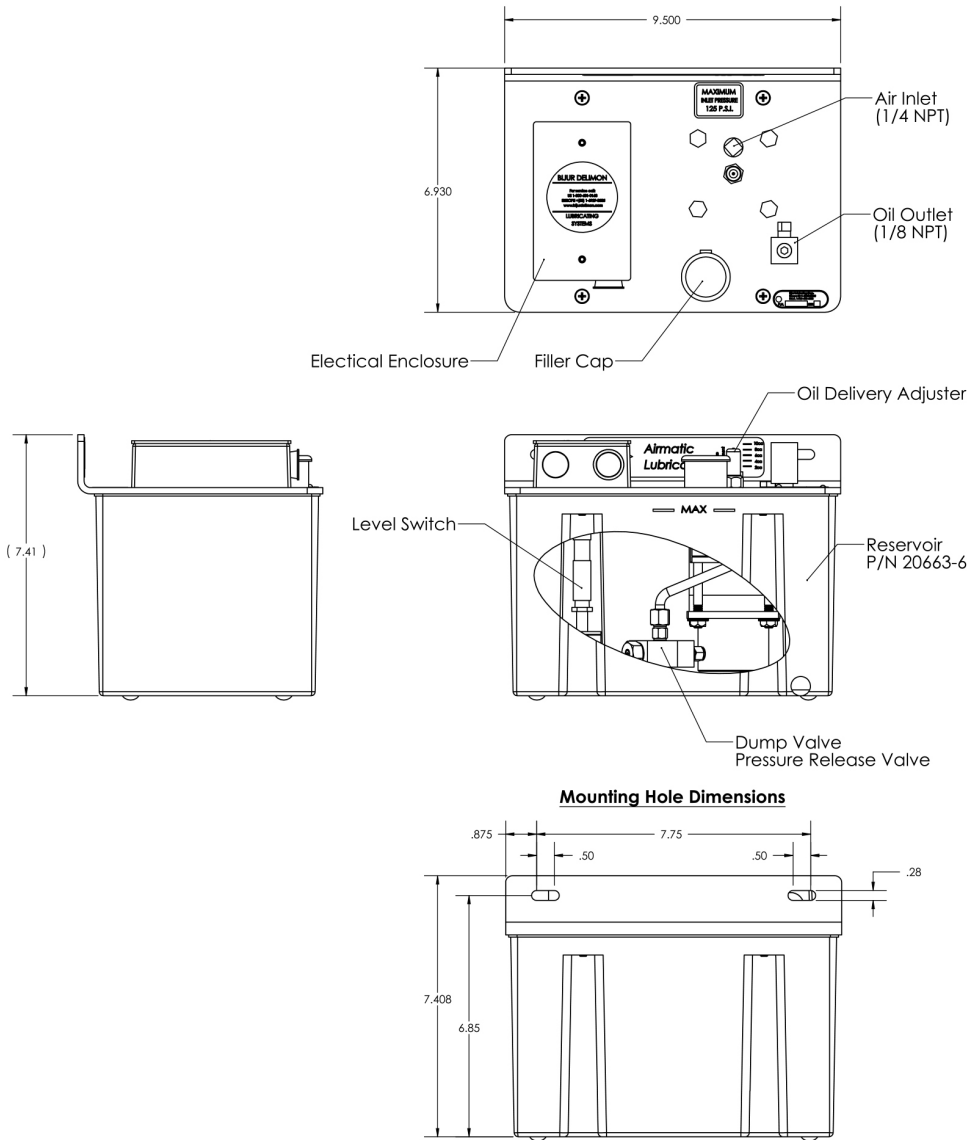



Dimensional Schematics

Measurements shown in inches.

12 Liter Model

