

# SB

## Bodies for Screw in Cartridge Valves



- Pipeline housing for cartridge valves
- Installation dimensions to ISO 4401 and SAE JS14
- Materials available are aluminium and steel

# Ordering Code

SB-□ □ - □ □ □

Screw in cartridge, Body

Form boring:  
3/4 - 16 UNF - 2B

A

Body material

Aluminium  
Steel, Surface treatment Zn

AL  
ST

Number of ways

2  
3  
4

Connecting size

G3/8  
SAE 6

03  
02

Body configuration

01

# Body for 2-Way SIC Valve

Dimensions millimeters (inches)

Body material	Pressure	Weight
Aluminium	up to 250 bar (3626 PSI)	0.35 kg (0,77 lbs)
Steel	up to 420 bar (6091 PSI)	0.98 kg (2,16 lbs)

## Body configuration 01

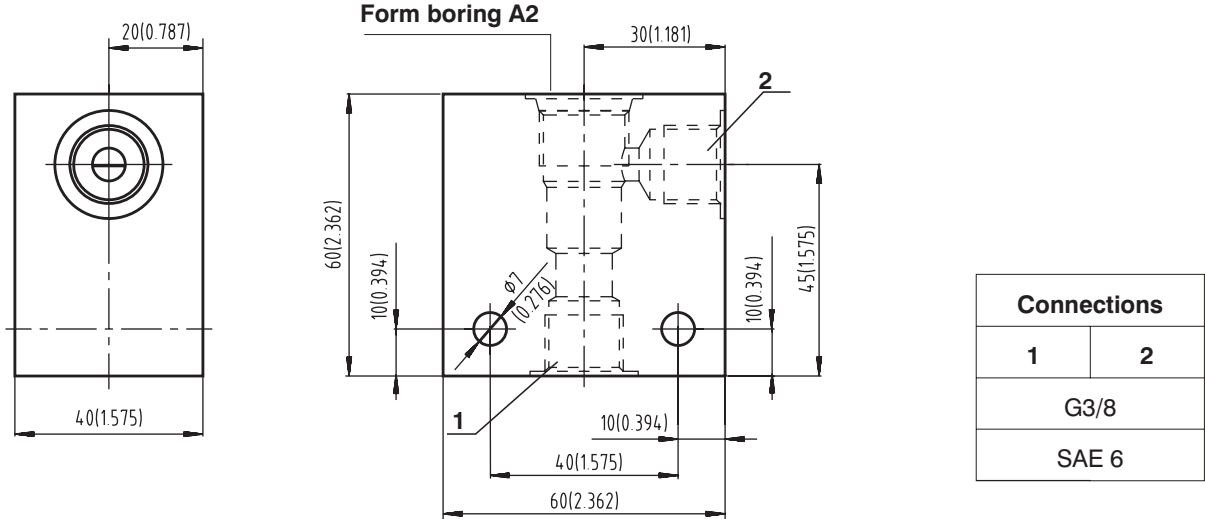

# Body for 3-Way SIC Valve

Dimensions millimeters (inches)

Body material	Pressure	Weight
Aluminium	up to 250 bar (3626 PSI)	0,48 kg (1,05 lbs)
Steel	up to 420 bar (6091 PSI)	0,45 kg (0,99 lbs)

## Body configuration 01

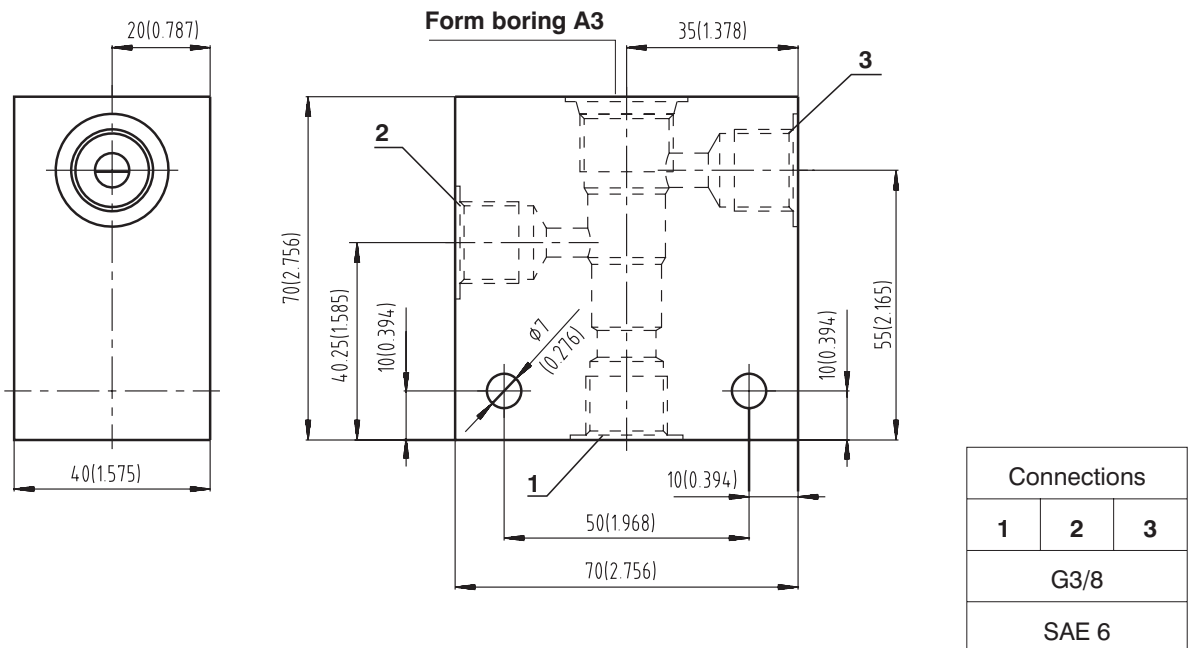

# Body for 4-Way SIC Valve

Dimensions millimeters (inches)

Body material	Pressure	Weight
Aluminium	up to 250 bar (3626 PSI)	0,54 kg (1,19 lbs)
Steel	up to 420 bar (6091 PSI)	0,53 kg (1,17 lbs)

## Body configuration 01

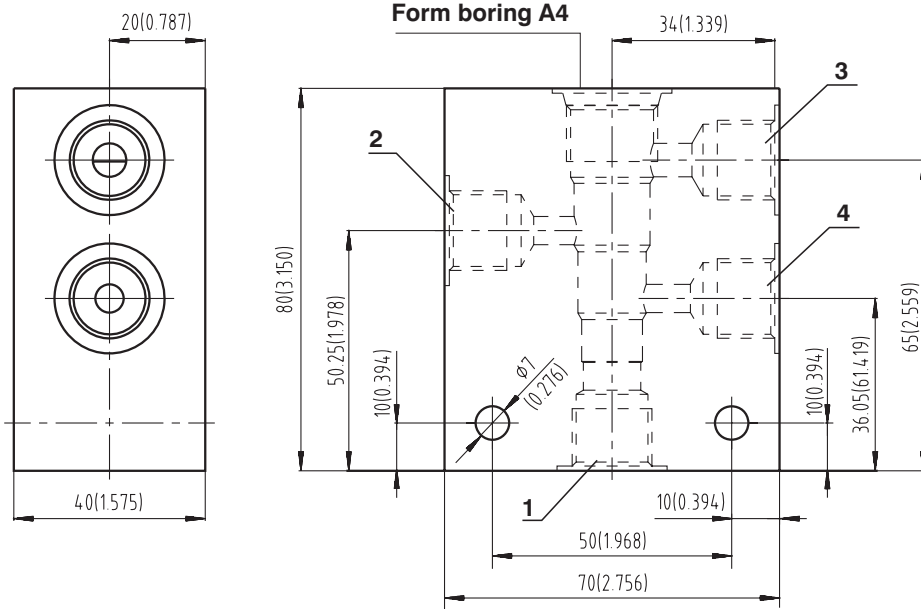

Connections			
1	2	3	4
G3/8			
SAE 6			

## Caution!

- Recommended fixing bolts M6 x 55 DIN 912-10.9, bolt tightening torque 14+2 Nm (10.33+1.48 lbf.ft)
- The packing foil is recyclable.
- The technical information regarding the product presented in this catalogue is for descriptive purposes only. It should not be construed in any case as a guaranteed representation of the product properties in the sense of the law.